

# Optimization of wing efficiency vs. sweep angles using mesh morphing

M. E. Biancolini , U. Cella  
University of Rome Tor Vergata  
Rome, Italy

M. Mancini, G. Travostino  
Piaggio Aero Industries s.p.a.  
Finale Ligure, Italy

Email: [biancolini@ing.uniroma2.it](mailto:biancolini@ing.uniroma2.it)  
Web: [www.rbf-morph.com](http://www.rbf-morph.com)

## Summary

This study has been conducted within a Research partnership, active since 2009, between Piaggio Aero Industries and University of Rome Tor Vergata. The collaboration was addressed to the solution of the aeroelastic problem, using the RBF Morph mesh morphing software, and recently extended to shape optimization methods. This paper describes this extension integrating the tools in an optimization environment aimed to the design of an aircraft wing.

A wind tunnel model of a business class aircraft in complete configuration, tested by Piaggio in the ONERA S2MA transonic facility, was used as baseline geometry. Sweep angles of two wing regions, in which the leading edges was kept straight and the wing reference area maintained constant, were selected as design variables. The relative movement between root section, kink section and wing tip was imposed using a two step morphing strategy. RBF Morph was first applied to the wing surface reshape (step 1) and then to the surrounding volume extending the morphing to a mesh sub domain delimited by a user defined bounding box (step 2). The quality of the mesh was verified in the full range of variation of both modifiers.

The baseline geometry was analyzed by CFD and parameterized using custom parameters to update the shape. The new geometries were analyzed using the flow solution of baseline geometry as starting solution. Such strategy permitted to significantly reduce the time to convergence of the new evaluations (500 iteration for a restarted solution against 1500 starting from scratch).

Lift and Drag coefficients were exported as output parameters ( $C_D$ ,  $C_L$ ) and used by the Workbench to derive the aerodynamic efficiency as objective function of the design problem. MOGA algorithm was applied and Kriging response surface (optimal space filling points + validated optimal candidates) estimated.

A wide range of efficiency variation (25%) was observed in the design space but, as expected, very slight improvements of the baseline solution (less than 1%) was achieved. On the other hand the wing was already optimized in the aircraft design stage, a valuable performance improvement would then have been surprising. The objective of the work was, in fact, to test the robustness and the performance of the design method.

The baseline solution is located near the maximum of the optimal area where the response surface exhibits a flat behavior confirming the quality of the starting design.

## Keywords

wings, sweep angles, mesh morphing, CFD

## Introduction

During the last three years, Piaggio Aero Industries, s.p.a. worked with the University of Rome Tor Vergata to develop and validate a design optimization method based on the generation of a single mesh, as a starting point, and on its morphing to any new geometry to be studied. The morpher tool used is RBF Morph. It allows to change the locations of nodes in the computational mesh, to change the shape of the wing and to match the surrounding surface and volume mesh to the new shape. The method was successfully applied to an aeroelastic problem, in which the aerodynamic solution was coupled to the structural analysis, in order to estimate the aerodynamic performance of an elastic structure [3]. In this work, its extension into an optimization environment is described. Ansys DesignXplorer was used to drive the morpher to map out the complete design space of an aircraft wing design problem and to identify its optimum.

The test case, used to verify the efficiency of the method, is the design of the wing of a Piaggio business jet class aircraft. The wing was already optimized applying both predevelopment and direct aerodynamic design methods. It was also experimentally tested in the ONERA transonic wind tunnel. Figure 1 shows the installation of the model in the test facility.

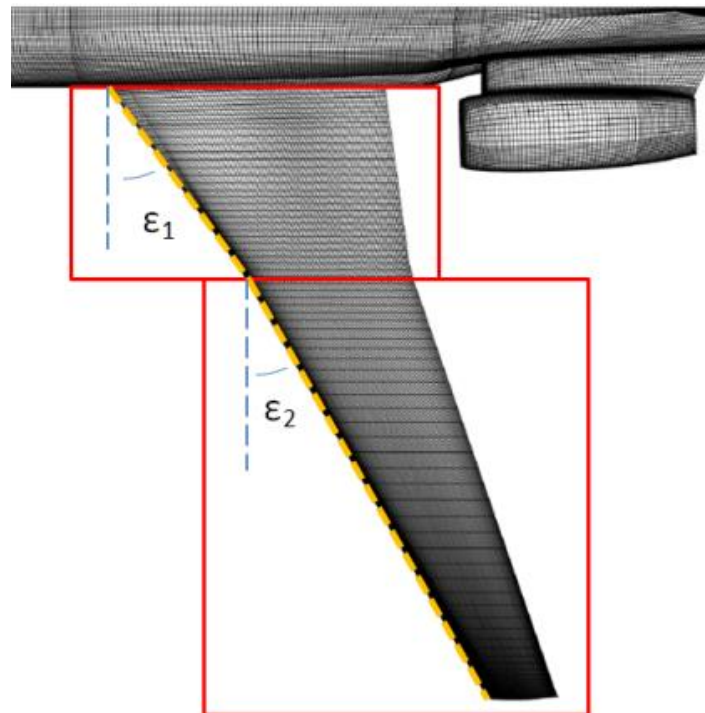

**Figure 1: Wind tunnel model installation**

The goal of the study was to maximize the aerodynamic efficiency (lift-to-drag ratio). A higher L/D leads directly to better fuel economy, climb performance and glide ratio.

## Problem setup

The wing leading edge is divided into two parts, each with a different sweep angle (angle between the leading edge of the wing and a line perpendicular to the axis of the aircraft fuselage). A kink is located between the two parts. The key design variables are the sweep angles of each leading edge part (figure 2).



**Figure 2: Computational mesh and design parameters**

An accurate structured 14 million hexahedral cells mesh on complete aircraft configuration was generated using Ansys ICEM CFD. The more traditional direct design cycle would have been to solve the CFD model, evaluate the results, modify the geometry and recreate the mesh to analyze the modified wing geometry. The new method

uses the RBF Morph software to change the wing shape and surrounding computational mesh to solve a series of design points without having to manually create a new geometry and mesh.

## The morphing tool

The morpher uses a series of radial basis functions (RBFs) to produce a solution for the mesh movement using source point inputs and their displacements (two shape parameters in this case). RBFs are very light weight compared to storing all the meshes that are created. The morpher incorporates a volume mesh smoother that preserves the volume mesh quality during morphing. The morphing operation can be executed in a matter of seconds, even on very large meshes, by using the parallel processing capabilities of high performance computing (HPC) clusters.

In this work, a two steps approach has been used to carefully control wing shapes whilst maximizing the quality of the volume mesh after morphing. First step set-up is addressed to surface morphing; sweep angles are controlled imposing a translation in the flight direction to external wing sections and constraining the inner. Second step set-up uses as input for wing surface movement the result of the first step. The morpher changes the locations of nodes in an encapsulation region (figure 3) defined by a bounding box with constrained boundary. It then adjust, in the originally generated computational mesh, the surrounding surface and volume mesh to match the new shape which is applied within the solver without needing to reload the mesh. The CFD solver can then continue from a previously converged solution without the need to start a new run from scratch.

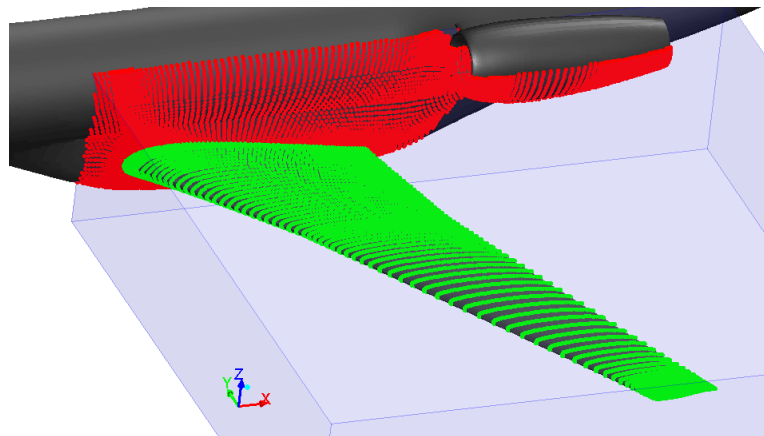

**Figure 3: bounding domain of mesh morphing**

The cruising conditions was imposed in the CFD configuration. The baseline model analysis required about 1,500 iterations for a complete convergence. The following evaluations, which started from the baseline solution, required only about 500 iterations to converge. Lift and Drag were exported as output parameters and used to calculate the design objective.

## The optimization procedure

The geometry modification and the CFD analysis were coupled with Ansys DesignXplorer optimization tool. The Workbench platform provided seamless interconnections for the inter-application data transfer.

The Multi-Objective Genetic Algorithm (MOGA) optimization method was used as searching criterion. The optimizer sequentially drive all of the design points analysis and collated the outputs of the simulations. A single evaluation cycle consisted in sending the first set of parameter values, representing the first shape, to the CFD solver, driving the morpher to morph the shape to the new one, running the CFD solver and passing the output results to the optimizer which stores the results. The process continued until the CFD solutions for all the design points were completed.

Design of Experiments (DOE) was used to identify a small sample of design points to represent the design space in such a way that when the aerodynamic performance was calculated at this small set of points, it could be interpolated with Ansys DesignXplorer to predict the performance of any other design point within the design space. A response surface using Kriging regression analysis from the collected data set of objective functions

was generated (figure 4). The response surface gives a rapid estimation of the objective function over the entire design space and intuitively provide the feeling on how it is dependent upon the chosen design parameters.

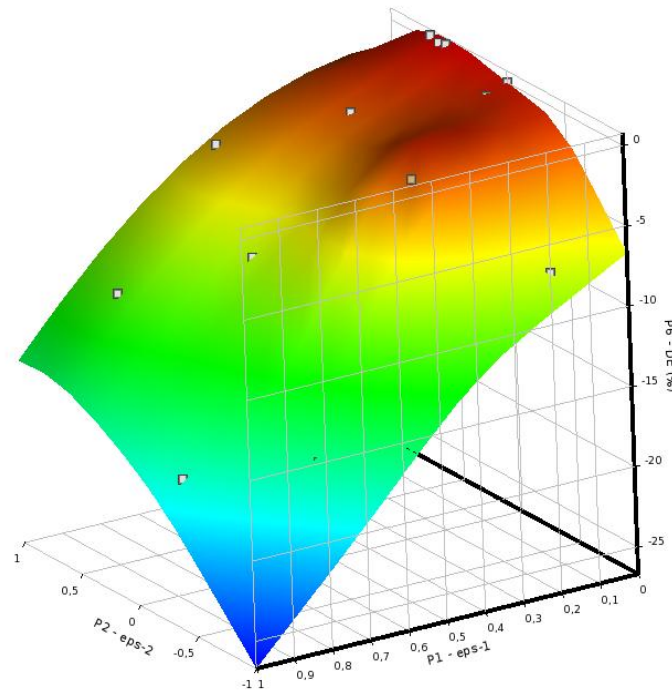

Figure 4: Response surface

## Conclusions

The optimization cycle was completed in a couple of weeks. The estimation of the response surface made it possible to evaluate the robustness of the various design candidates. The most robust designs are those in regions of the response surface with the least slope. As expected a very slight performance improvement (less than 1%) was obtained. As mentioned the aircraft wing of the test case was already the result of an accurate aerodynamic design process. However, a wide design parameter space was investigated and the method showed to be robust and to have very interesting potentialities. It demonstrated to be a powerful tool able to improve the engineers design capabilities ready to be integrated in an high performance industrial design process.

## References

- [1] Biancolini, M. E., Mesh Morphing Accelerates Design Optimization, in the ANSYS Advantage Magazine - Volume IV, Issue 1, 2010.
- [2] Biancolini, M. E., Mesh Morphing and Smoothing by Means of Radial Basis Functions (RBF): A Practical Example Using Fluent and RBF Morph in Handbook of Research on Computational Science and Engineering: Theory and Practice (2012), IGI Global, ISBN13: 9781613501160.
- [3] Cella, U. and Biancolini, M. E.. Aeroelastic Analysis of Aircraft Wind-Tunnel Model Coupling Structural and Fluid Dynamic Codes, Journal of Aircraft, Vol. 49, No. 2 (2012), pp. 407-414.