



# Shape optimization of the MIRA Reference CAR



**Gianluca Orso Fiet**  
**MIRA UK**

**The application of a CFD-optimisation process in the Automotive Industry could be beneficial for:**

- **reducing overall development time**
- **generating a robust design in early stages of a project**

# Test Case Description



## MIRA Reference Car

Idealised vehicle geometry with three modular back-shapes.  
Estate-back configuration was used for this study.

 MIRA

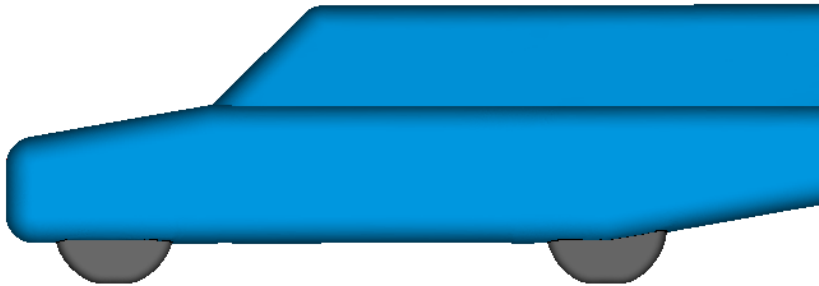

 MIRA

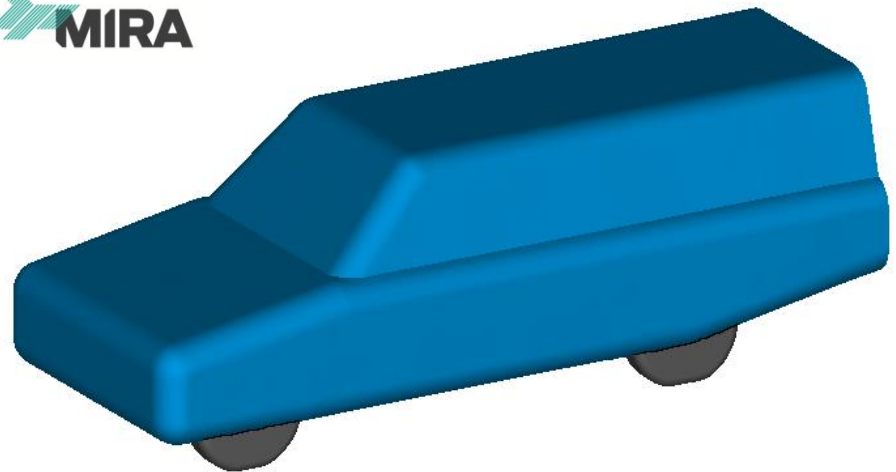

# Target of the Study

The main target of the morphing/optimisation process was to reduce drag while keeping a required level of downforce ( $C_L = -0.2$ ).

The exterior shape of the vehicle was modified by:

1. Boat-tailing of top rear back
2. Changing the angle of roof
3. Changing angle of rear diffuser

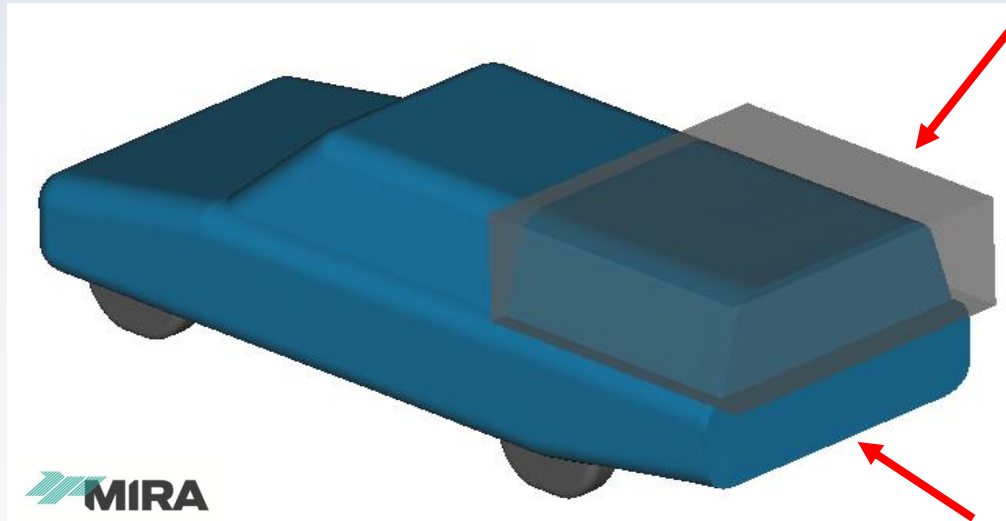

# Target of the Study

The main target of the morphing/optimisation process was to reduce drag while keeping a required level of downforce ( $C_L = -0.2$ ).

The exterior shape of the vehicle was modified by:

1. Boat-tailing of top rear back
2. Changing the angle of roof
3. Changing angle of rear diffuser

*Initial Shape*

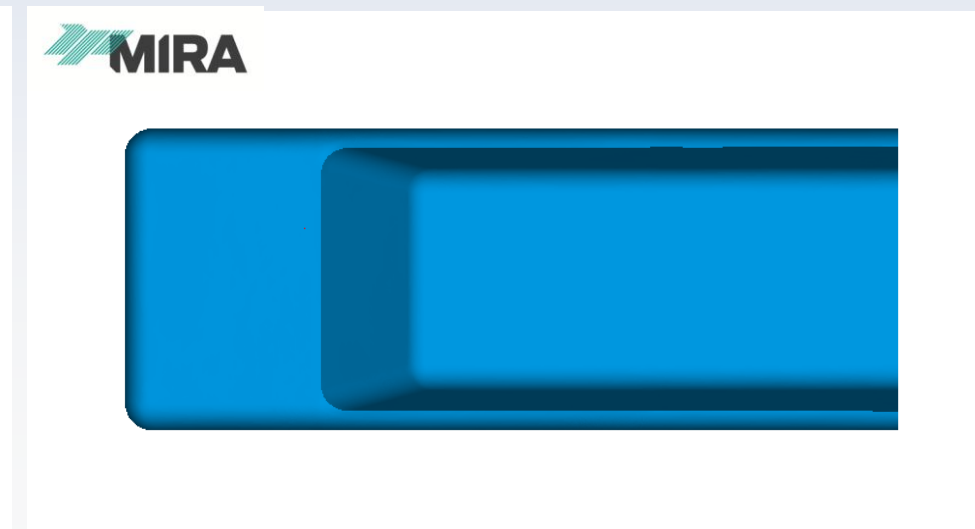
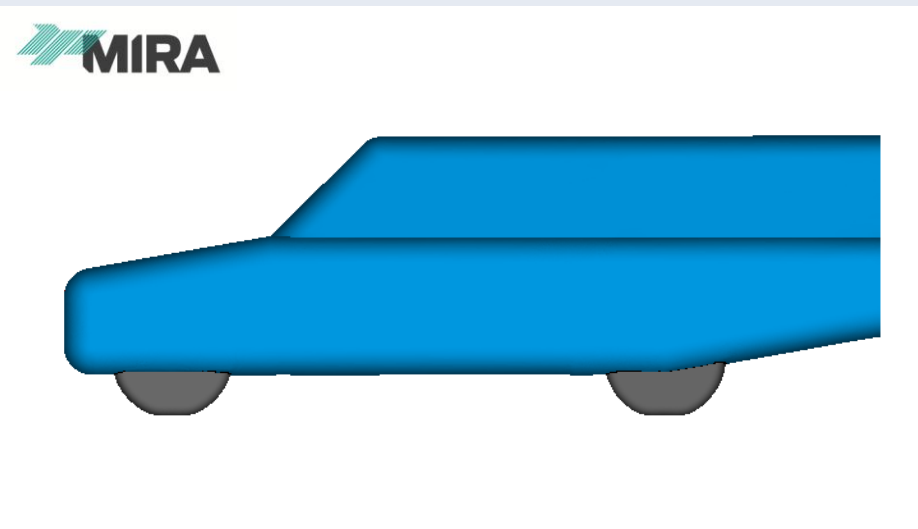

# Target of the Study

The main target of the morphing/optimisation process was to reduce drag while keeping a required level of downforce ( $C_L = -0.2$ ).

The exterior shape of the vehicle was modified by:

1. Boat-tailing of top rear back
2. Changing the angle of roof
3. Changing angle of rear diffuser

*Morphed Shape*

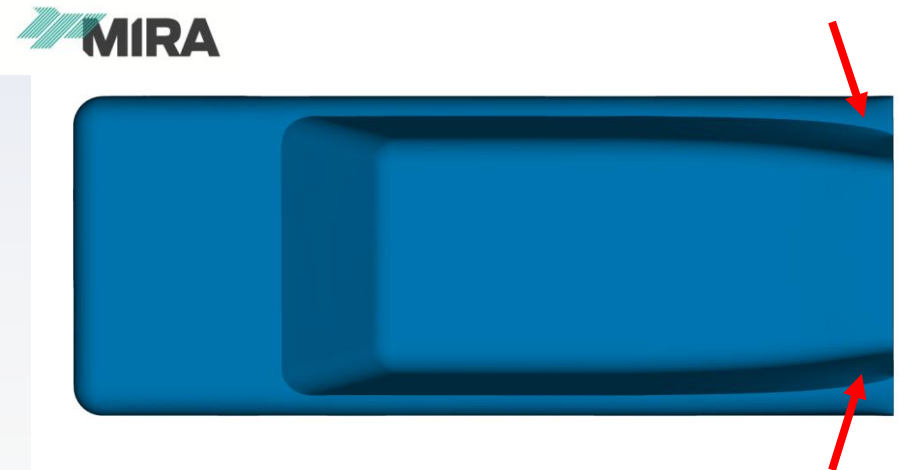
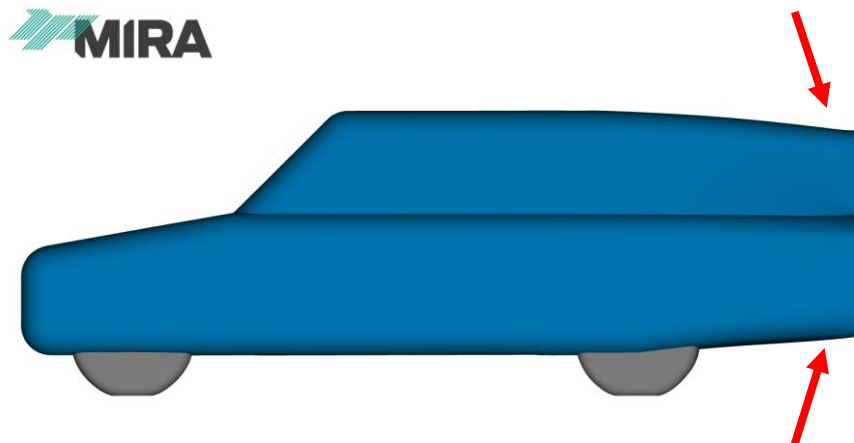

# Solution strategy



1. Shape modifiers are defined in RBF Morph
2. Full Factorial DOE set-up using RBF Morph (**27 design points to be fully calculated**)
3. Batch solution (using a single case and .rbf & .sol file of each shape, symbolic links in DOE folders)
4. Post processing using a MathCAD worksheet for the evaluation of Response Surface (RS); RS is evaluated using RBF in generic n-dimensional spaces
5. Optimal point detection exploring metamodel in a fine DOE (about 70000 designs explored in a few seconds!)
6. New CFD run at optimal point (**minimum drag with downforce constraint**)

# Solution: shape 1

- Shape 1 “back”
- 1 Domain box
- Surface controlled moving side edges
- Sym option activated
- 1184 RBF points
- 1 s to fit
- 30 s to morph
- Range [0:1]
- Max amplitude 10cm

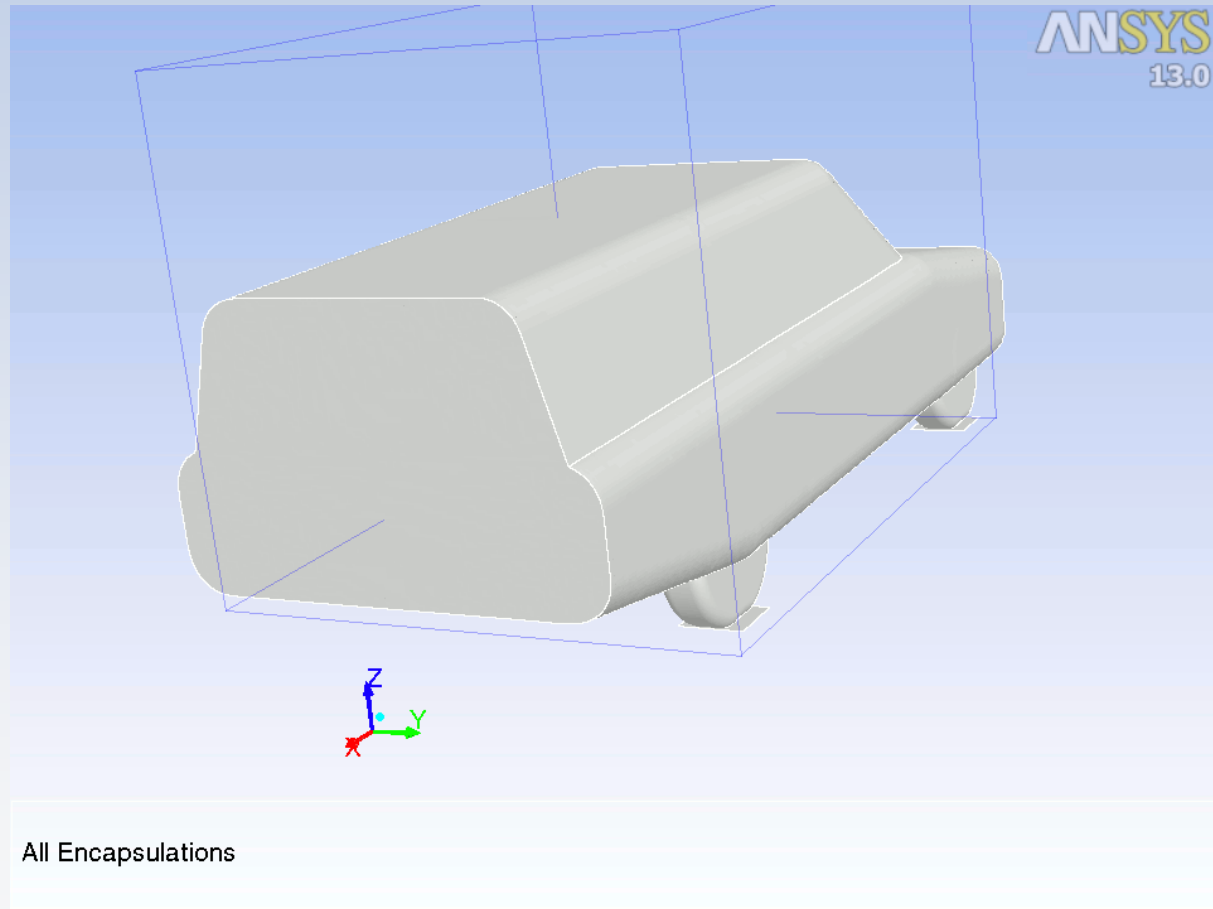



# Solution: shape 2

- Shape 2 “roof”
- 1 Domain box
- Surface controlled scaling rear edges
- 6685 RBF Points
- 3 s to fit
- 75 s to morph
- Range [0:1]
- Max amplitude 10.5cm

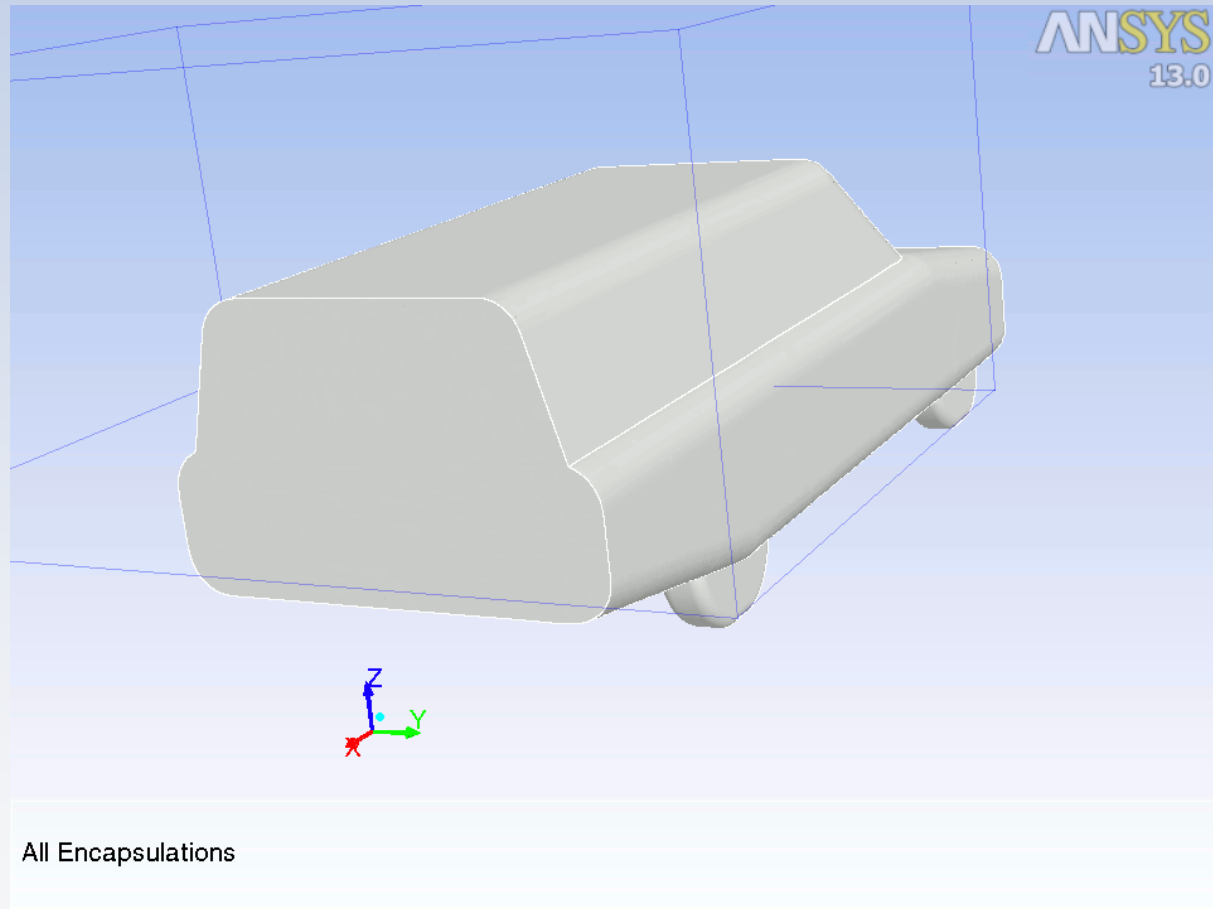

# Solution: shape 3

- Shape 3 “diffuser”
- 1 Domain box
- Surface controlled in two steps (edges + RBF sol on Surf)
- Sym option activated
- 33650 RBF Points
- 25 s to fit
- 131 s to morph
- Range [-1:1]
- Max amplitude +/- 10.1cm

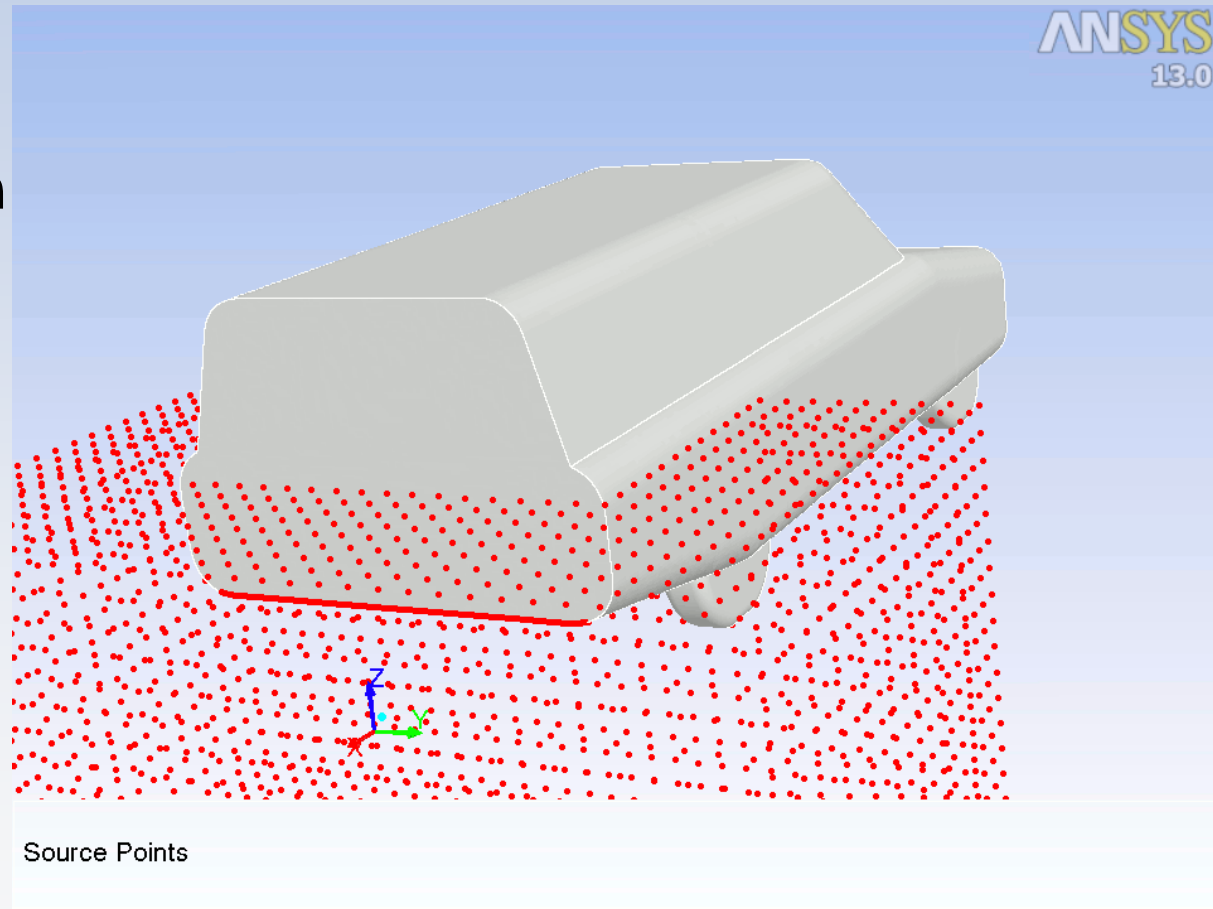

Source Points

# Results: morphing

- First morphing test

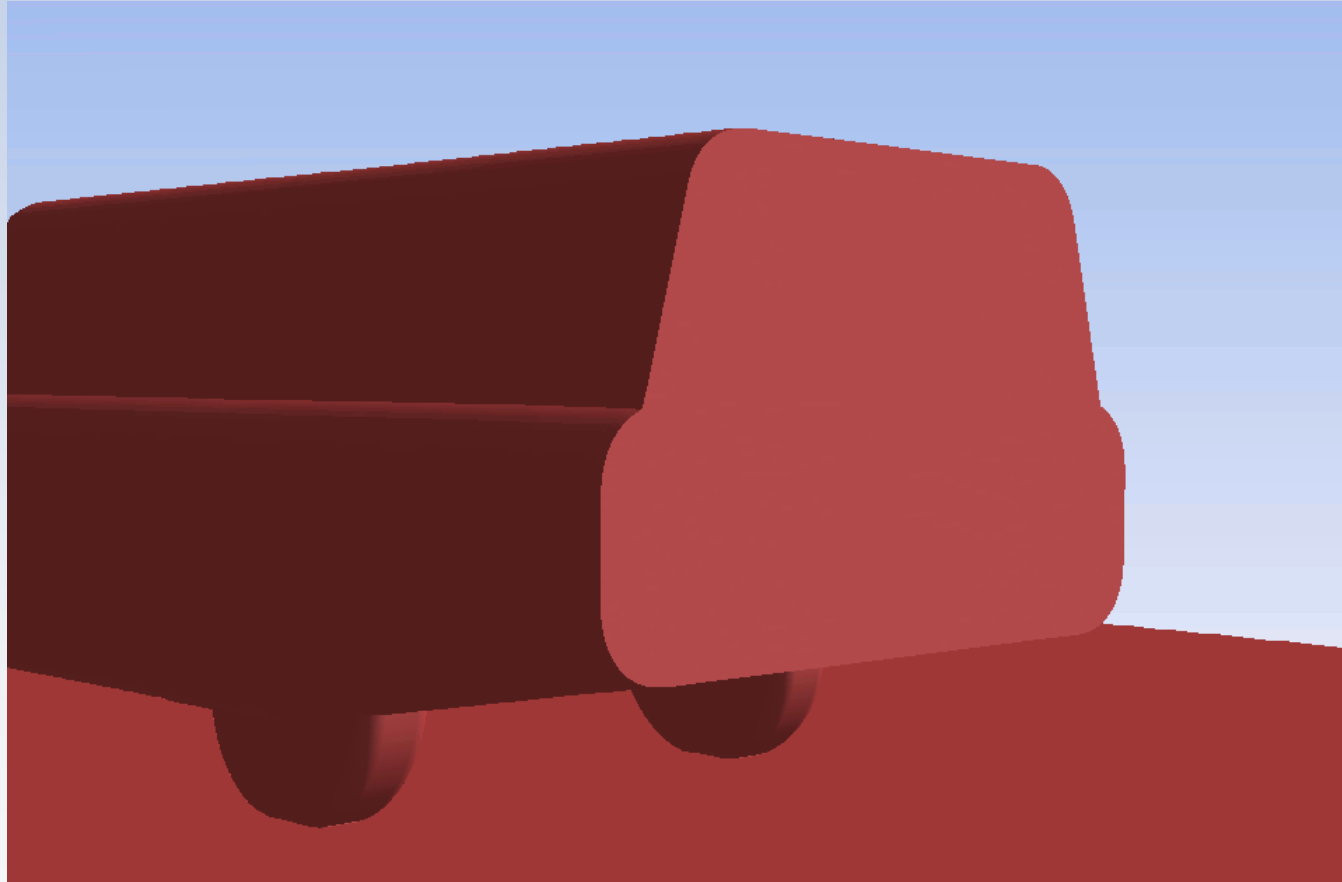

Morphing Preview (A=0)

# Results: morphing



- Explored design points

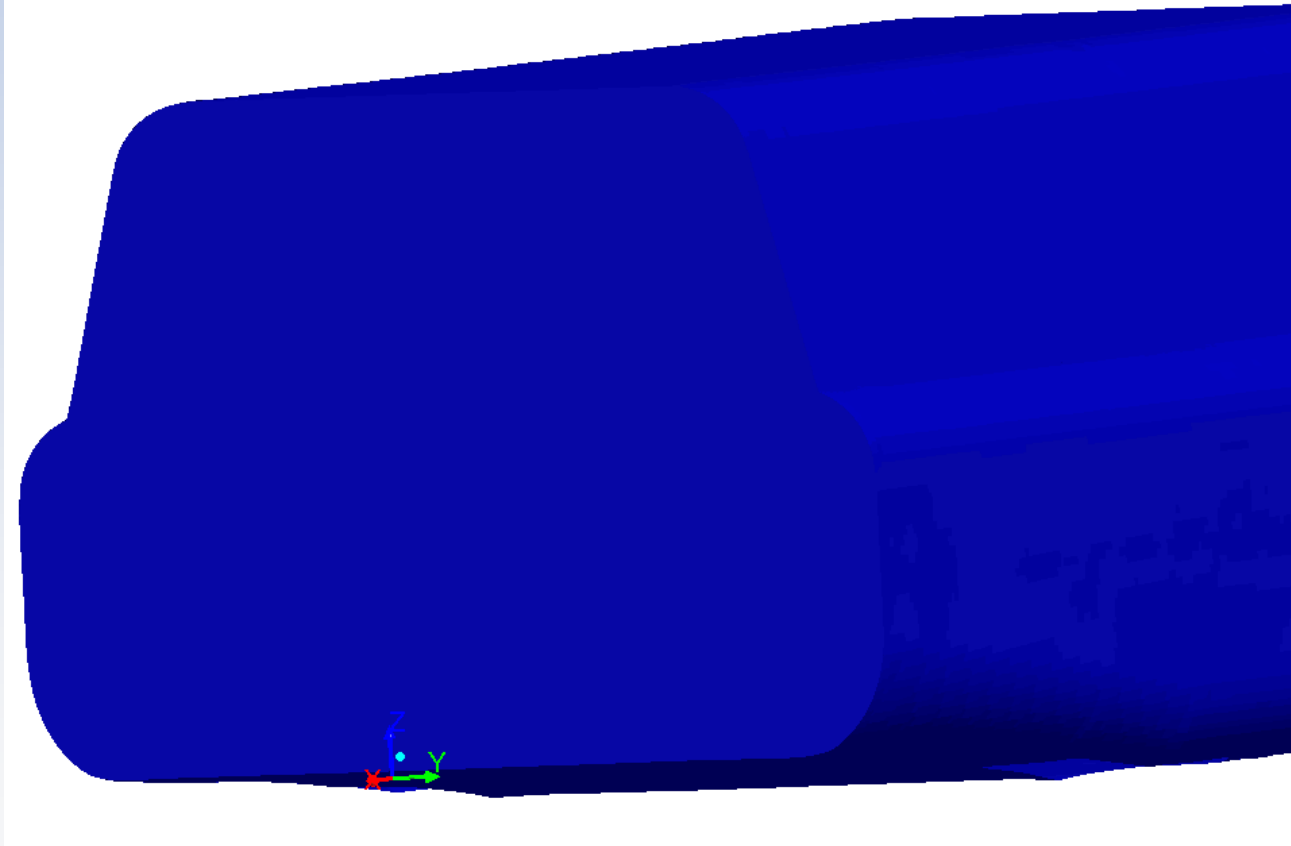

Morphing Preview (A1=0, A2=0, A3=-1)  
[www.rbf-morph.com](http://www.rbf-morph.com)

**(rbf-morph)<sup>TM</sup>**

# Results: DOE post processing



## • Explored design points

Config	C <sub>D</sub>	C <sub>L</sub>	C <sub>My</sub>	C <sub>LF</sub>	C <sub>LR</sub>	back	roof	diffuser
1	0,299	-0,217	0,050	-0,059	-0,158	0	0	-1
2	0,335	-0,361	0,116	-0,065	-0,296	0	0	0
3	0,360	-0,414	0,142	-0,065	-0,349	0	0	1
4	0,282	-0,176	0,030	-0,058	-0,118	0	0,5	-1
5	0,319	-0,324	0,096	-0,065	-0,258	0	0,5	0
6	0,340	-0,368	0,117	-0,067	-0,301	0	0,5	1
7	0,284	-0,142	0,017	-0,054	-0,087	0	1	-1
8	0,306	-0,286	0,079	-0,064	-0,222	0	1	0
9	0,322	-0,320	0,092	-0,068	-0,252	0	1	1
10	0,290	-0,197	0,104	0,005	-0,203	0,5	0	-1
11	0,320	-0,326	0,090	-0,073	-0,253	0,5	0	0
12	0,342	-0,383	0,120	-0,071	-0,312	0,5	0	1
13	0,273	-0,159	0,016	-0,063	-0,095	0,5	0,5	-1
14	0,299	-0,284	0,070	-0,072	-0,212	0,5	0,5	0
15	0,321	-0,328	0,091	-0,073	-0,255	0,5	0,5	1
16	0,260	-0,123	-0,001	-0,062	-0,060	0,5	1	-1
17	0,282	-0,242	0,048	-0,073	-0,169	0,5	1	0
18	0,304	-0,294	0,075	-0,072	-0,222	0,5	1	1
19	0,285	-0,176	0,022	-0,066	-0,110	1	0	-1
20	0,314	-0,301	0,076	-0,075	-0,226	1	0	0
21	0,338	-0,352	0,102	-0,074	-0,278	1	0	1
22	0,267	-0,140	0,004	-0,066	-0,074	1	0,5	-1
23	0,293	-0,262	0,056	-0,075	-0,187	1	0,5	0
24	0,316	-0,325	0,088	-0,074	-0,251	1	0,5	1
25	0,254	-0,105	-0,012	-0,064	-0,041	1	1	-1
26	0,275	-0,224	0,038	-0,075	-0,150	1	1	0
27	0,295	-0,275	0,063	-0,074	-0,201	1	1	1

# Results: DOE post processing



- Sensitivity Analysis (3 inputs, 4 outputs)**

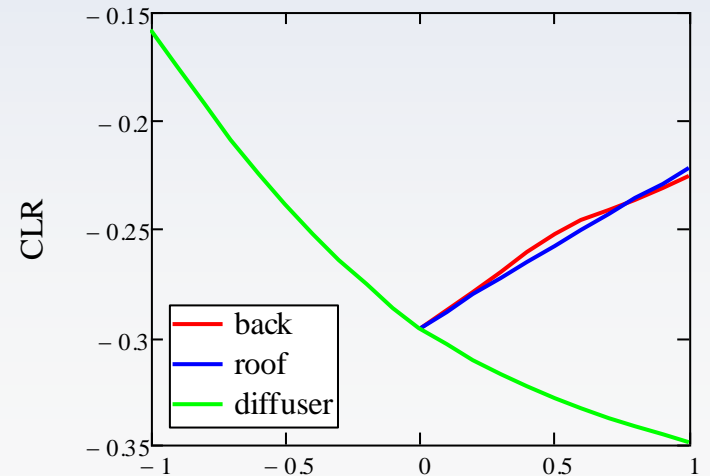
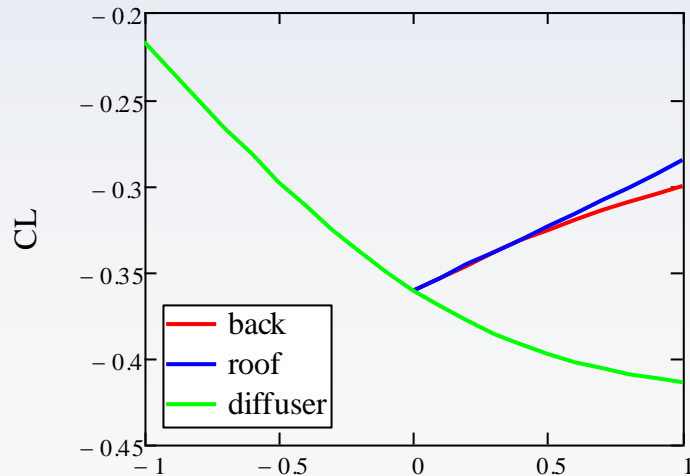
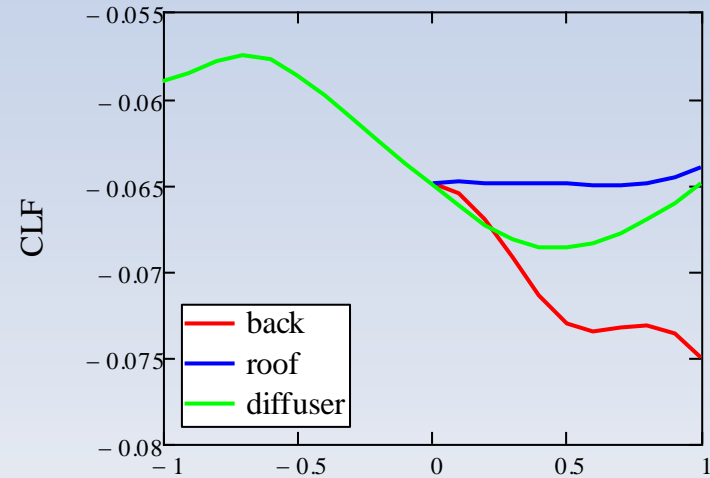
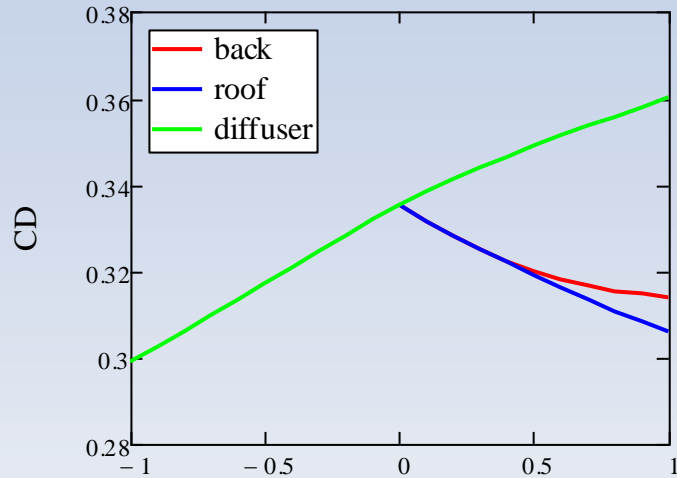

# Results: DOE post processing



- Optimal point selection on a fine Full Factorial DOE evaluated on the Response Surface (68921 designs)

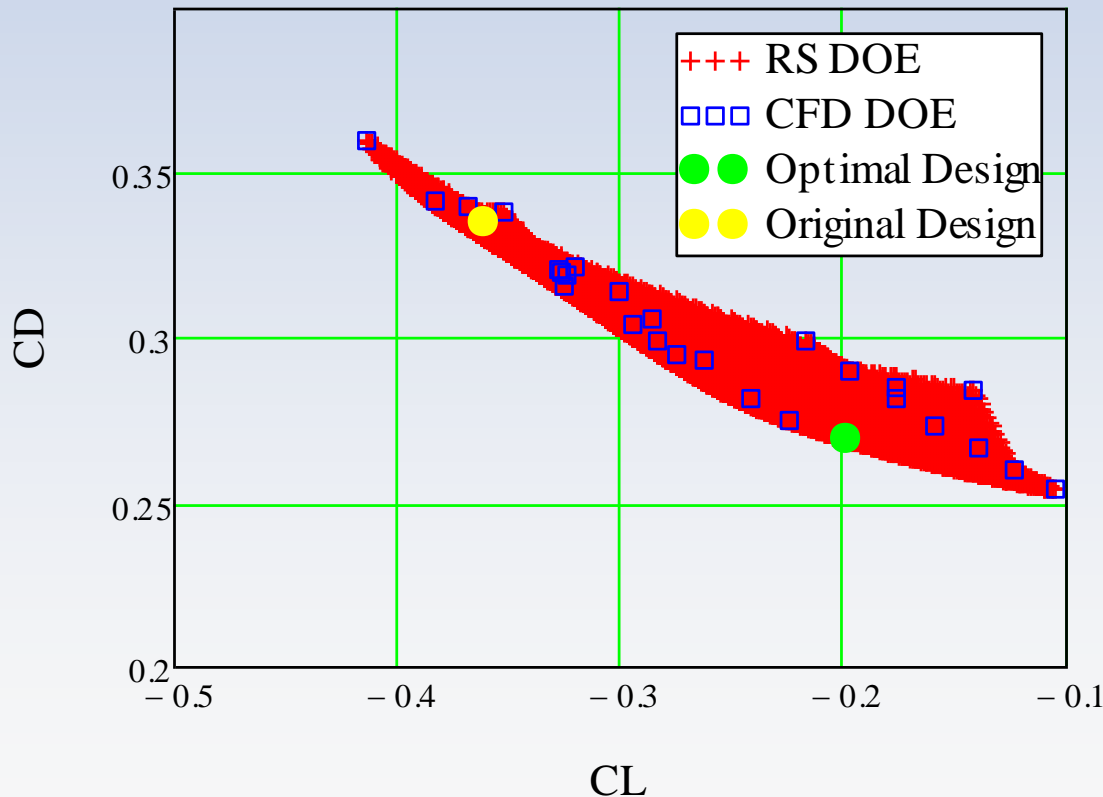

$$\begin{pmatrix} \delta_1 \\ \delta_2 \\ \delta_3 \end{pmatrix} = \begin{pmatrix} 0.875 \\ 1 \\ -0.3 \end{pmatrix} \begin{pmatrix} \text{back} \\ \text{roof} \\ \text{diffuser} \end{pmatrix}$$

$$\text{change} = \begin{pmatrix} -19.686 \\ -45.029 \\ -75.793 \\ 10.292 \\ -56.994 \end{pmatrix} \cdot \% \begin{pmatrix} \text{CD} \\ \text{CL} \\ \text{CMY} \\ \text{CLF} \\ \text{CLR} \end{pmatrix}$$

# Results: CP



Optimised configuration resulted in 20% drag reduction while maintaining the required level of downforce.

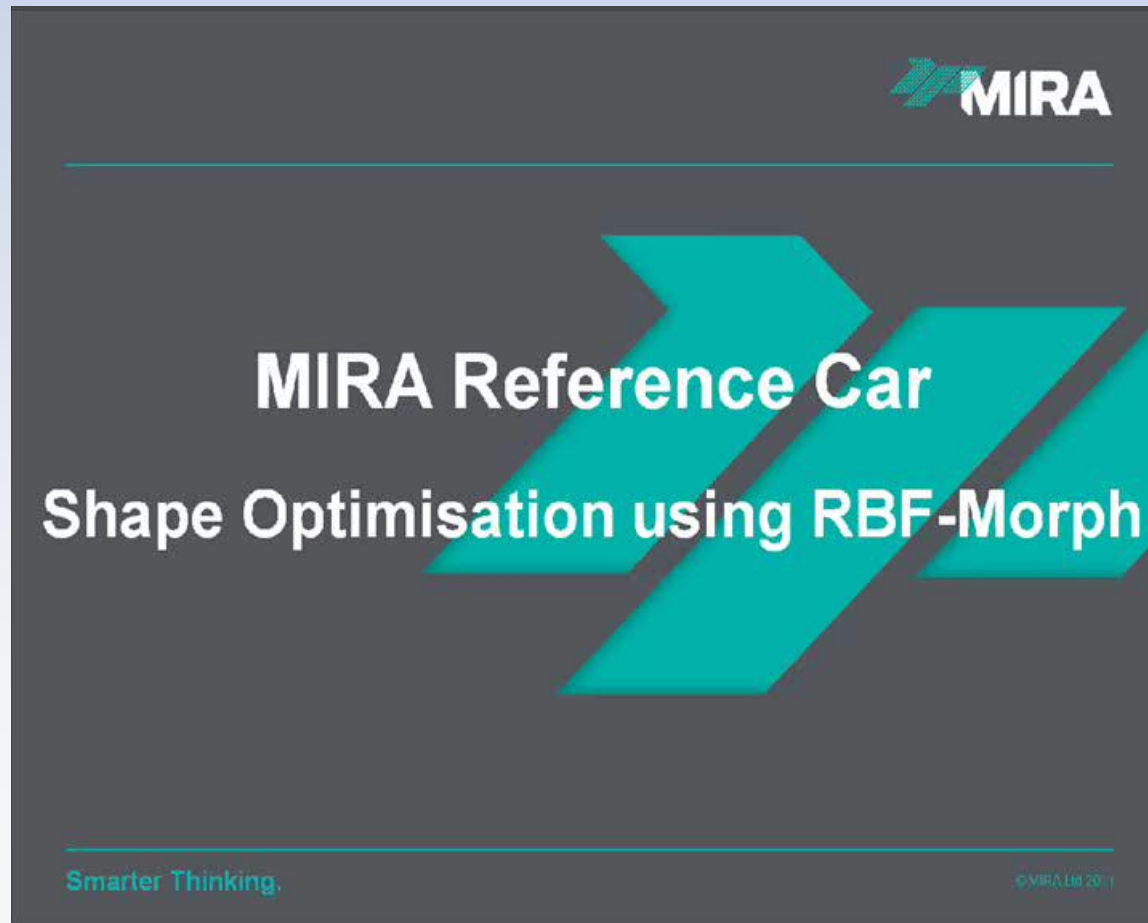



# Results: path-lines



Results from RBF-Morph DOE study showed a very good agreement with trends measured in the MIRA wind tunnel.

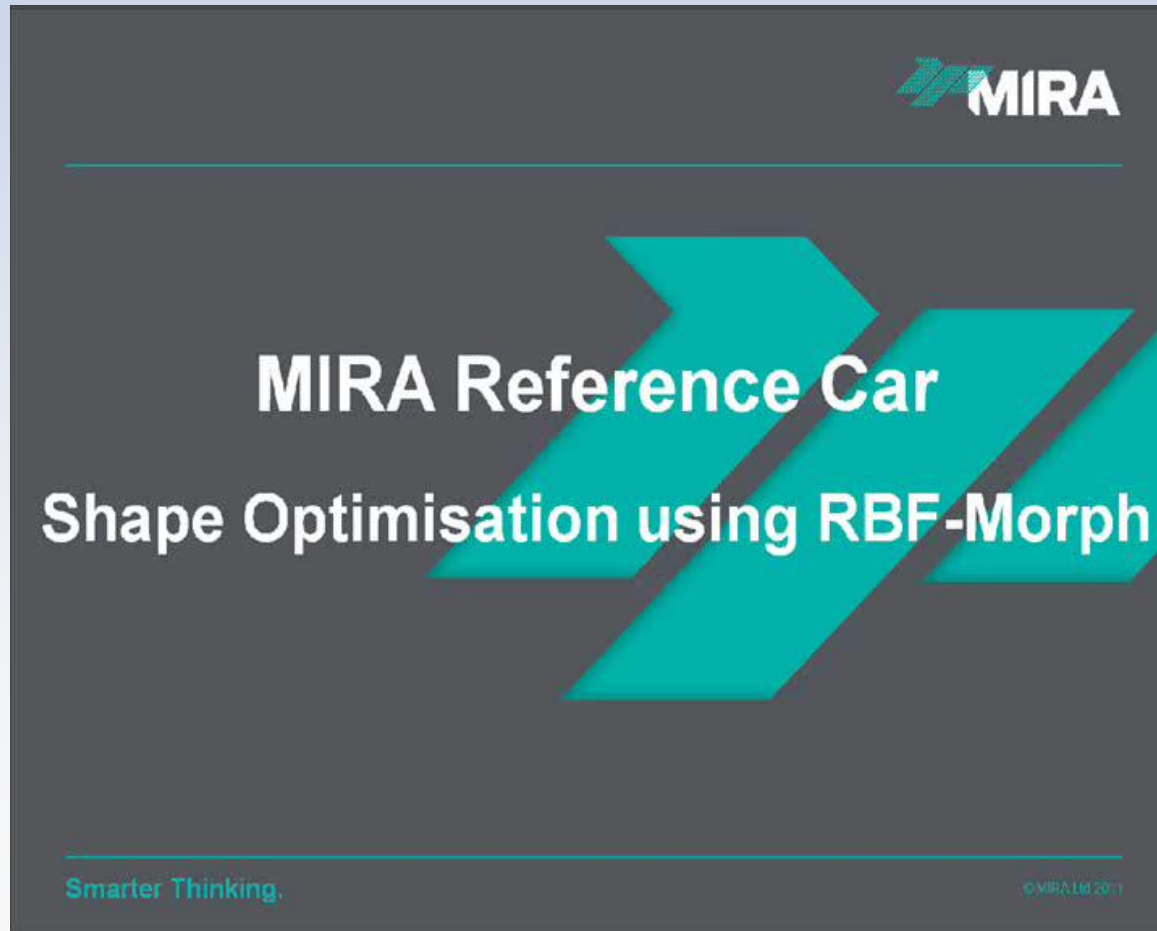

# Results: performances



- **Mesh generated with SnappyHexMesher – 0.3 hour (clock time)**
- **Mesh size: 5.2 millions poly cells**
- **Case set-up – 1 hour**
- **RBF Morph Set-up – 1 day**
- **DOE Running set-up – 1/2 day**
- **Running - 300 hours (clock time)**
- **CFD results post-processing – 1 day**
- **DOE data post-processing – 1 day**

## Significant human time reduction for the shape optimisation process:

- Standard Approach – Manual geometry modification and remeshing: **estimated human time from CAD to results**  
 **$5 \times 27 = 135$  hours**
- RBF-Morph – 1 initial case and mesh morphing: **human time from CAD to results ~ 40 hours**