



**TOR VERGATA**  
UNIVERSITÀ DEGLI STUDI DI ROMA

**Cycle XXXIV**



**Edoardo Pompa**

for

**PhD Program in Design, Manufacturing and Operations  
Engineering**

# **An Investigation on Digital Twin Methodologies for the ITER Project**

Academic Institution: [University of Rome "Tor Vergata"](https://www.uniroma2.it), Italy

**Advisors:** Marco E. Biancolini (UTV), Gabriele D'Amico (F4E), Alessandro Lo Bue (F4E)



---

## Objective:

Investigate RE techniques for the development of a Digital Twin model of the ITER components in production.

The presentation is divided in three parts:

- **Reconstruction of non-ideal surface model:** development of a morphing procedure for the reconstruction of the manufactured shapes;
- **Association of measurements:** development of a tool for the verification of features surfaces in different stages of the manufacturing.
- **Virtual Fitting:** development of a tool for the alignment of measurements and fitting in vitro of components.



## International Thermonuclear Experimental Reactor

ITER will be the first fusion device (tokamak) designed to produce a ten-fold return on energy (500 MW of fusion power from 50 MW of input power).

$Q \geq 10$

International Nuclear Fusion R&D project (China, EU, India, Japan, Korea, Russia, USA).

Experimental Tokamak Nuclear Fusion Reactor being built in Cadarache (France).

Demonstrate that Fusion is a valuable source of energy

Study “burning” plasma  
Test key technologies

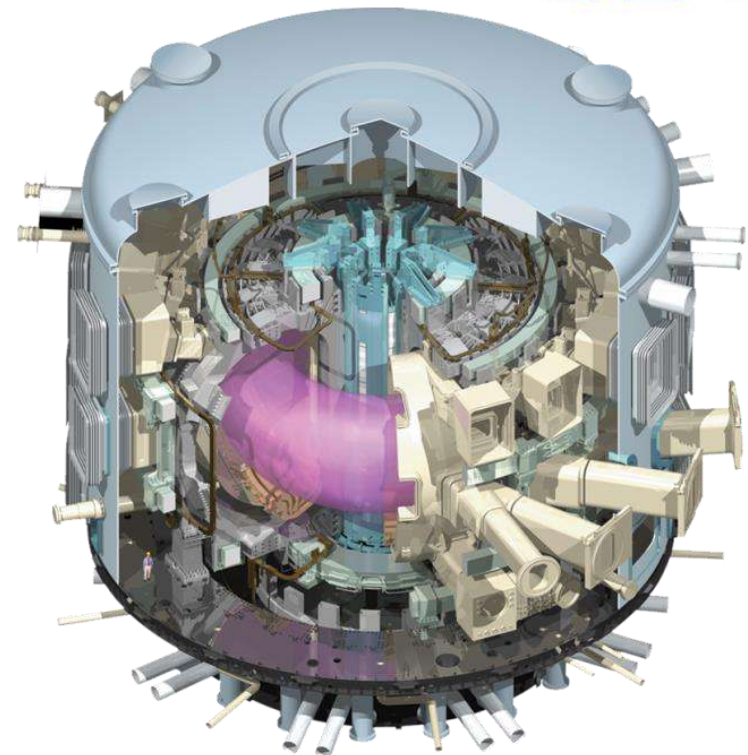

*ITER Machine (under construction in Cadarache, southern France)*

## Tokamak and nuclear fusion:

Tokamak: russian acronym for «toroidal chamber with magnetic coils»

Nuclear reaction from the stars reproduced on the earth:

- Extreme temperatures (150M °C)
- Strong magnetic fields (12 T)

*ITER Machine*

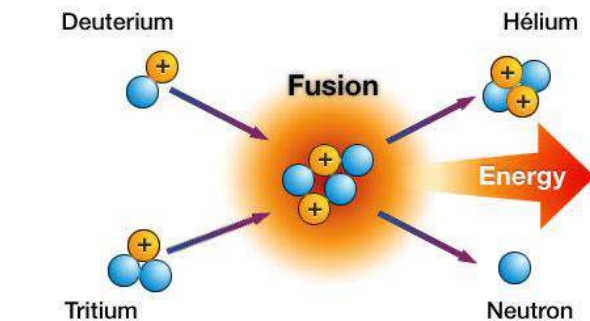

Heat coming from the reaction can be collected and used to produce energy.

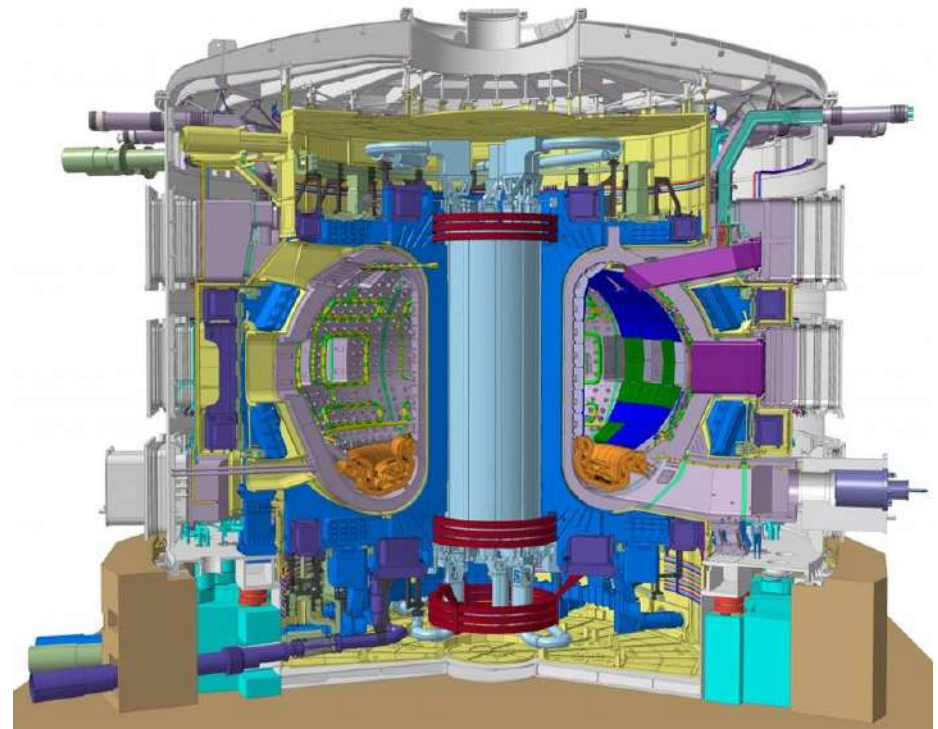

## The Vacuum Vessel:

Sealed steel, torus shaped vacuum chamber housing the plasma, made by 9 toroidal sectors (40° each)

Key functions of the component:

- First containment barrier against radiation and heat
  - Provides and assures high quality vacuum
  - Participates in removing the heat
  - Support for in-vessel components
- 
- The full chamber is composed by nine 40 degrees sections, called sectors.
  - During manufacturing, each of the sector is achieved by welding together four subcomponents, called segments

VV 40° sector

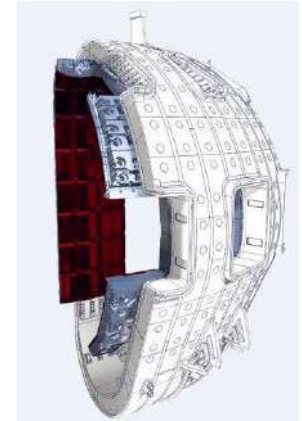

VV 320° view

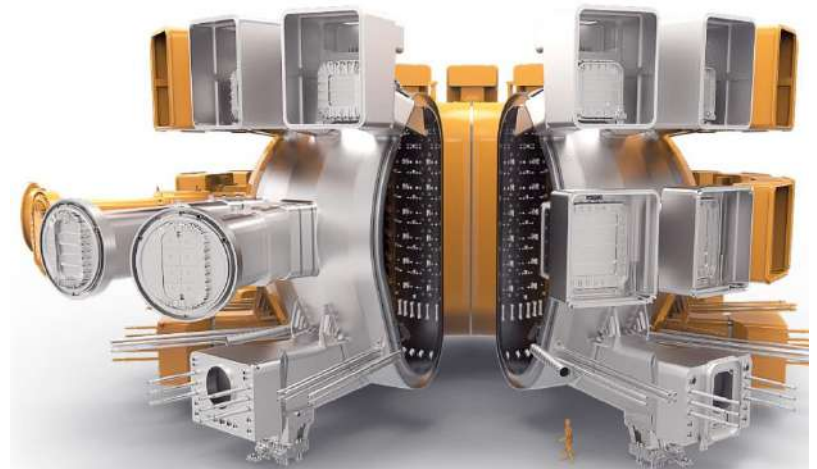

## The Toroidal Field coils:

18 D-shape Winding Packs (WP), enclosed in SS316LN cases (TFCC)

Key functions of the component:

- produce a peak magnetic field of around 12 T
- provide isolation to the superconductors
- provide structural integrity to the tokamak

- Each TFC is approximately  $16.5\text{ m} \times 9\text{ m}$  in size and 300 t in weight.
- In order to confine the plasma they are operated at a constant 68 kA

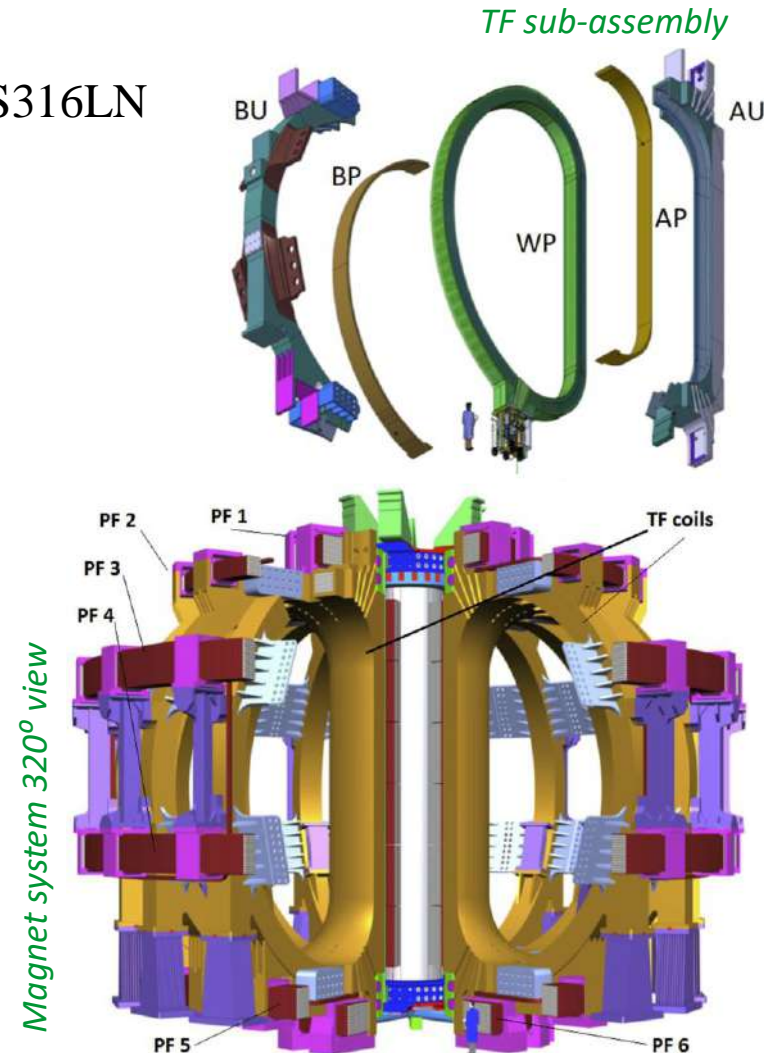



## Large volume components and metrology:

Tight tolerances on large volume components set a new challenge on the manufacturing. Gravity and thermal expansions can affect the compliance of the items with the final requirements. Metrology and Reverse Engineering techniques have to be embedded in the production.

ISO 17450-1 gives tools and methodologies for the development of Skin Models.

Skin Model is an infinite model of the physical interface between the workpiece and its environment. It allows a unified description of geometrical specification.

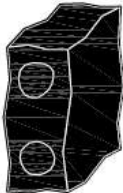
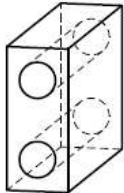
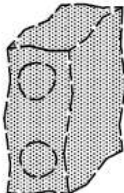
- Nominal and Non-Ideal Model
- Integral and Derived features
- Operations:
  - Partition
  - Association
  - Collection
  - Reconstruction

Taken from	Real surface of the workpiece	Nominal model	Surface model	
			Non-ideal surface model	
Illustration				
Integral feature	Real feature	Nominal integral feature	Example: extracted integral feature	Associated integral feature
Derived feature		Nominal derived feature	Example: extracted derived feature	Associated derived feature
Qualifier	Real	nominal	Examples: extracted; filtered; reconstructed	Associated
Type of geometrical feature	Non-ideal	Ideal	Non-ideal	Ideal

## Workflow:

A workflow of reconstruction of non-ideal Skin surface model has been developed on the TF WP and the VV IS.

- Acquisition of as-built data;
- Data preparation;
- Morphing;
- CAD reconstruction.

Positive aspects that make it a valuable choice are:

- capability to produce an updated shape with the initial **CAD topology**
- possibility to generate a displacements field **without a reference geometry**

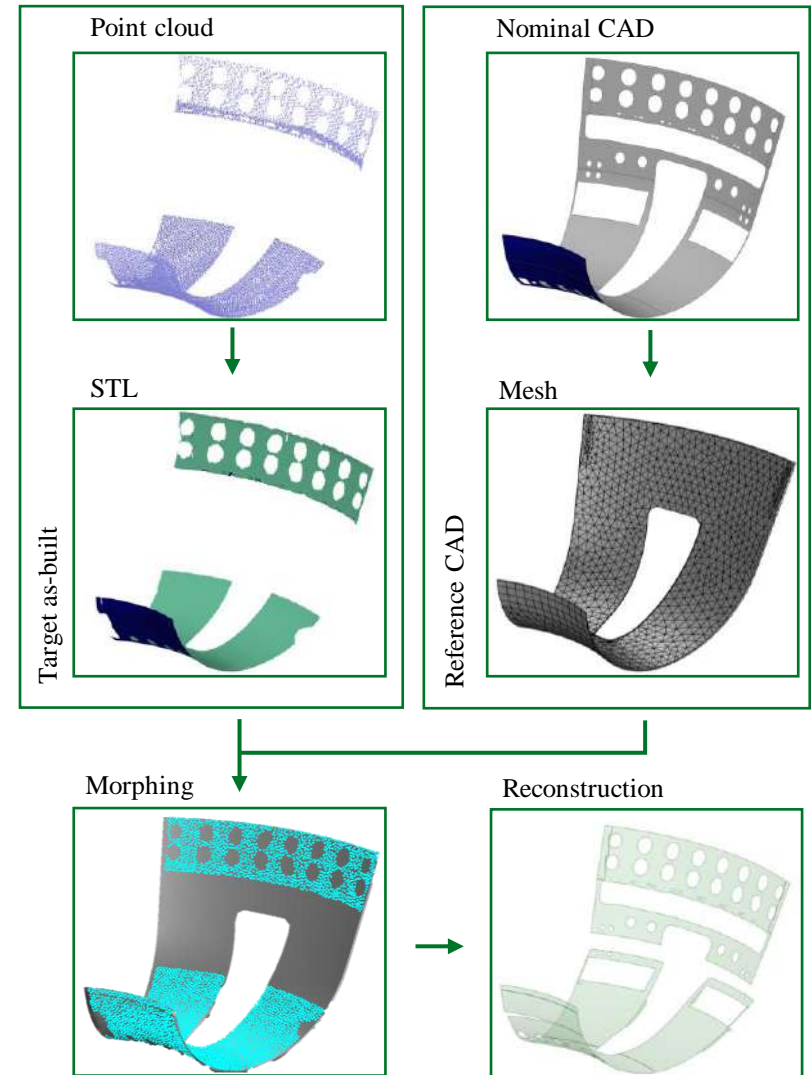



## Acquisition of as-built data: Measurement instrument and uncertainty

Uncertainty of measurement is the doubt that exists about the result of any measurement. Any instrument expresses its uncertainty of measurement in the calibration certificate.

*Mean value*

$$\bar{x} = \frac{\sum_{i=1}^n x_i}{n}$$

*Standard deviation*

$$s = \sqrt{\frac{1}{n-1} \sum_{i=1}^n (x_i - \bar{x})^2}$$

*Standard uncertainty*

$$u = \frac{s}{\sqrt{n}}$$

*Combined standard uncertainty*

$$CSU = k \sqrt{\sum_{j=1}^l u_j^2}$$

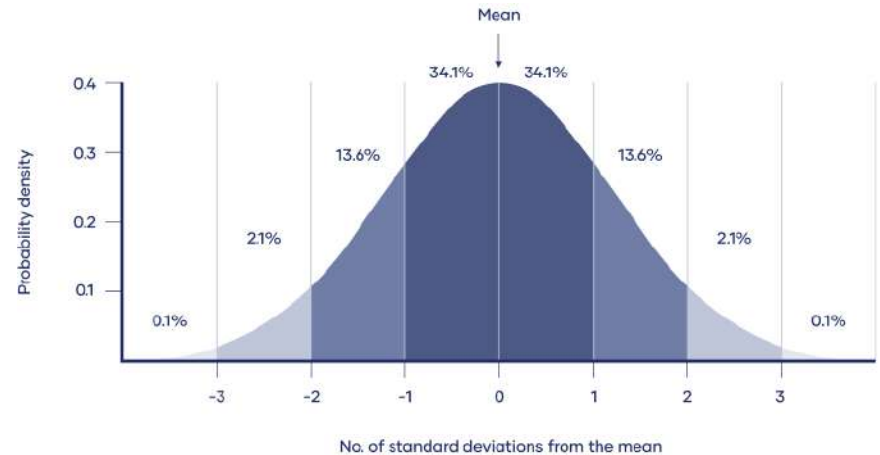

Mean value  $\pm$  CSU, at a level of confidence level of k

## Acquisition of as-built data: Measurement instrument and uncertainty

Blue light scans, photogrammetry and contact-based measurement systems are typically used for the acquisition of as-built data.

- PCMM scanners;
- Structured light 3D scanners;
- Laser scanners.

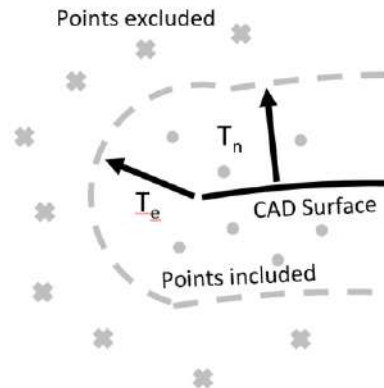
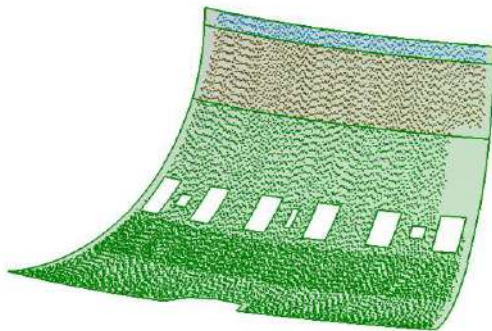

*Laser tracker and scanner head*

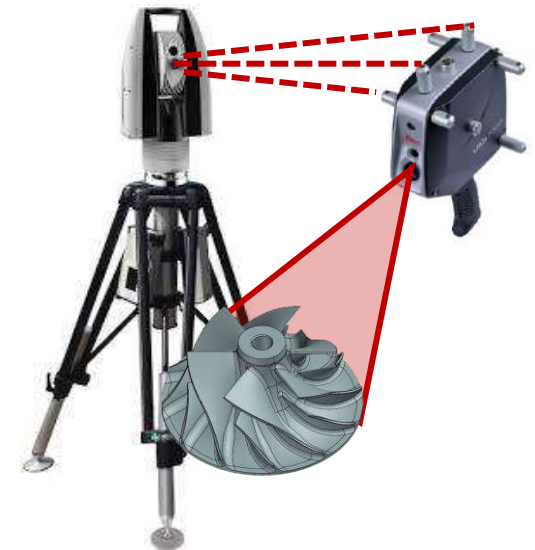

The outcome of the scan is a point cloud, (point coordinates XYZ).  
An algorithm filters the data on the nominal CAD topology.

## Data preparation: Triangulation

From the cloud points, the target STL is created by Delaunay triangulation, a technique which maximizes the minimum angle of triangles generated for a given set of points.

$$\begin{vmatrix} A_x & A_y & A_x^2 + A_y^2 & 1 \\ B_x & B_y & B_x^2 + B_y^2 & 1 \\ C_x & C_y & C_x^2 + C_y^2 & 1 \\ D_x & D_y & D_x^2 + D_y^2 & 1 \end{vmatrix} > 0$$

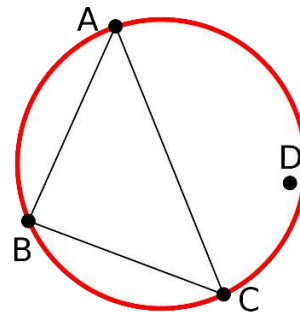

*Octoctemy triangulation*

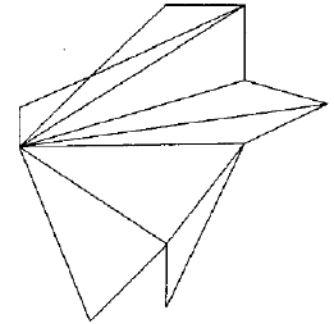

*Delaunay triangulation*

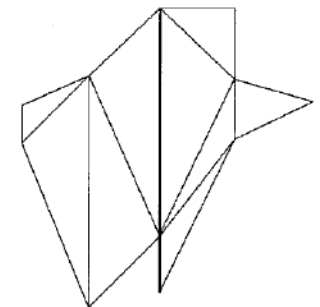

Combined with adaptive sizing algorithms, the Delaunay triangulation is used to obtain from the nominal CAD a homogeneous mesh. The corresponding nodes will be source points for the generation of the displacement fields in the morphing

## Morphing: STL target

The mesh source points from the nominal CAD are projected on the target STL. The displacement field on each point is generated by interpolating values through RBF morphing algorithm combined with Newton's iteration method.

*Interpolating function  $s(x)$*

$$s(\mathbf{x}) = \sum_{i=1}^N \gamma_i \left( \sqrt{(x - x_{s_i})^2 + (y - y_{s_i})^2 + (z - z_{s_i})^2} \right)^3 + h(\mathbf{x})$$

*Gradient of the function  $s(x)$*

$$\nabla s(\mathbf{x}) = \left\{ \frac{\partial s(\mathbf{x})}{\partial x} \quad \frac{\partial s(\mathbf{x})}{\partial y} \quad \frac{\partial s(\mathbf{x})}{\partial z} \right\}^T \begin{cases} \frac{\partial s(\mathbf{x})}{\partial x} = 3 \sum_{i=1}^N \gamma_i (x - x_{s_i}) \sqrt{(x - x_{s_i})^2 + (y - y_{s_i})^2 + (z - z_{s_i})^2} + \beta_1 \\ \frac{\partial s(\mathbf{x})}{\partial y} = 3 \sum_{i=1}^N \gamma_i (y - y_{s_i}) \sqrt{(x - x_{s_i})^2 + (y - y_{s_i})^2 + (z - z_{s_i})^2} + \beta_2 \\ \frac{\partial s(\mathbf{x})}{\partial z} = 3 \sum_{i=1}^N \gamma_i (z - z_{s_i}) \sqrt{(x - x_{s_i})^2 + (y - y_{s_i})^2 + (z - z_{s_i})^2} + \beta_3 \end{cases}$$

*Projection iteration*

$$\mathbf{x}_{k+1} = \mathbf{x}_k + \frac{s(\mathbf{x}_k)}{\|\nabla s(\mathbf{x}_k)\|^2} \nabla s(\mathbf{x}_k)$$

The above iteration runs until  $\|\mathbf{x}_{k+1} - \mathbf{x}_k\|$  is less than a given tolerance.

## NURBS patching:

From the morphed mesh, a B-spline patch is defined. Iterative methods based on linear least-squares optimization have been developed to solve this type of nested minimization problem.

*B-spline surface*

$$s_f(u, v) = \sum_{r=0}^{n_f} \sum_{s=0}^{m_f} d_{r,s}^f N_{r,k_f}(u) N_{s,l_f}(v)$$

*Functional to minimize*

$$E_{dist}(S) = \sum_{i=1}^N d^2(p_i, S)$$

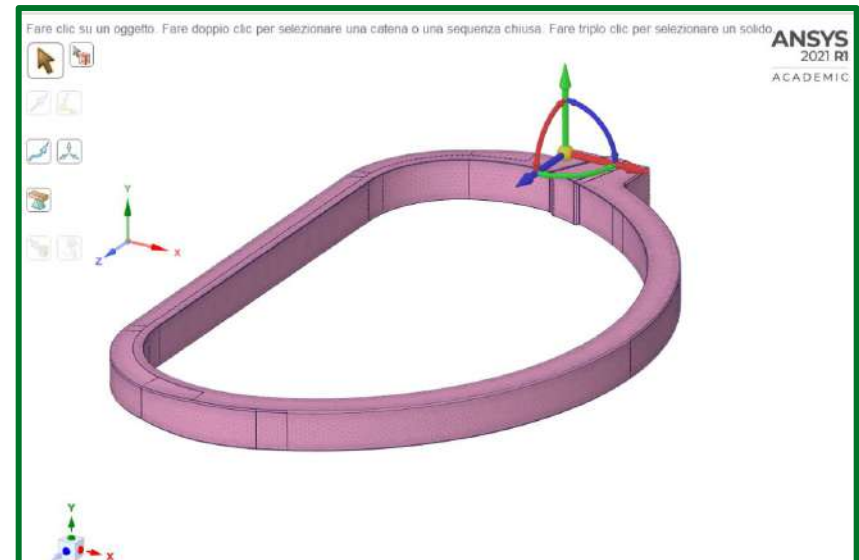

The full morphed CAD model can be reconstructed by automating the optimization of B-spline patching.

## Toroidal Field coil Winding Pack application:

A portion of the Toroidal Field Coil Winding Pack has been used in the test:

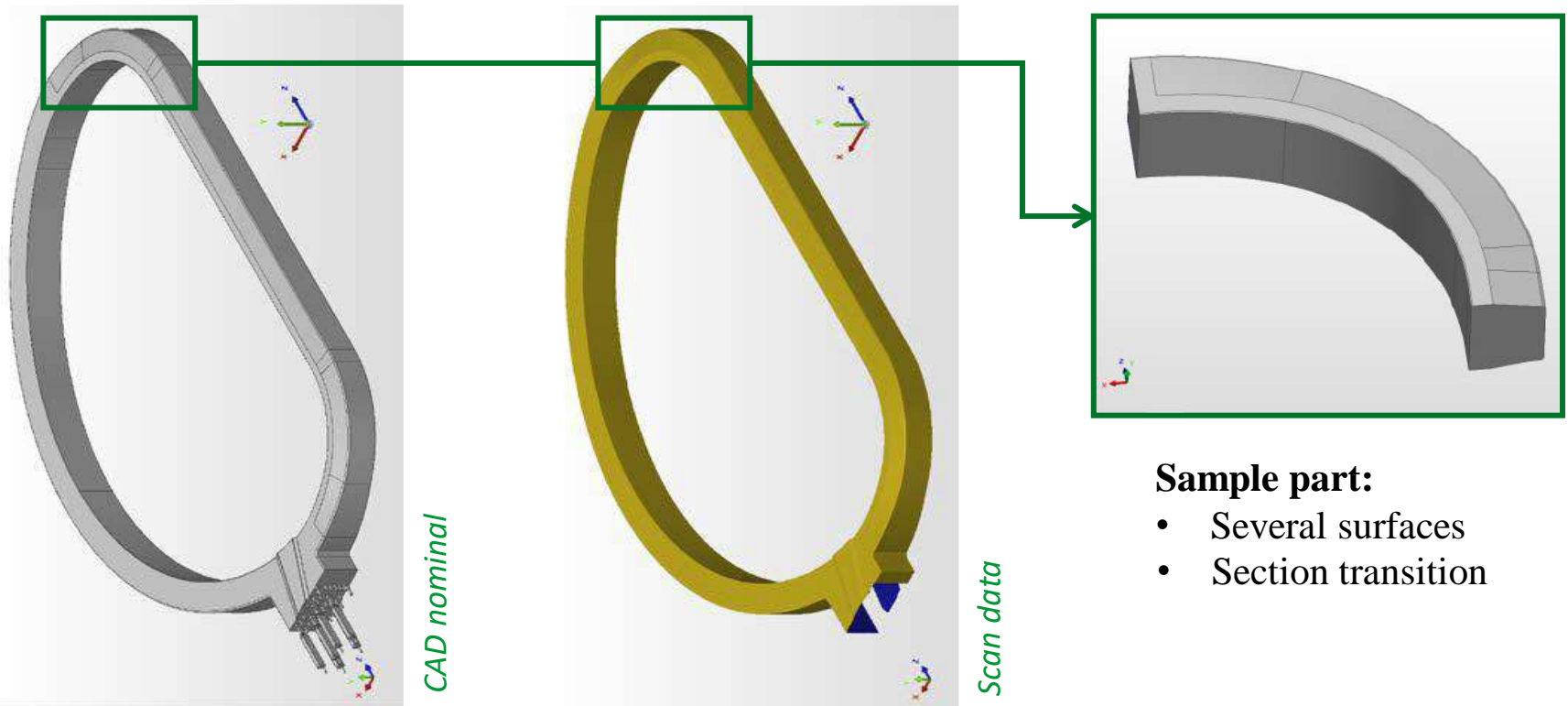

Scan process uncertainty:  $\pm 0.1$  mm

## Scan data deviation from nominal CAD:

Thinner top and bottom surfaces due to optimization of the double pancakes stacking.

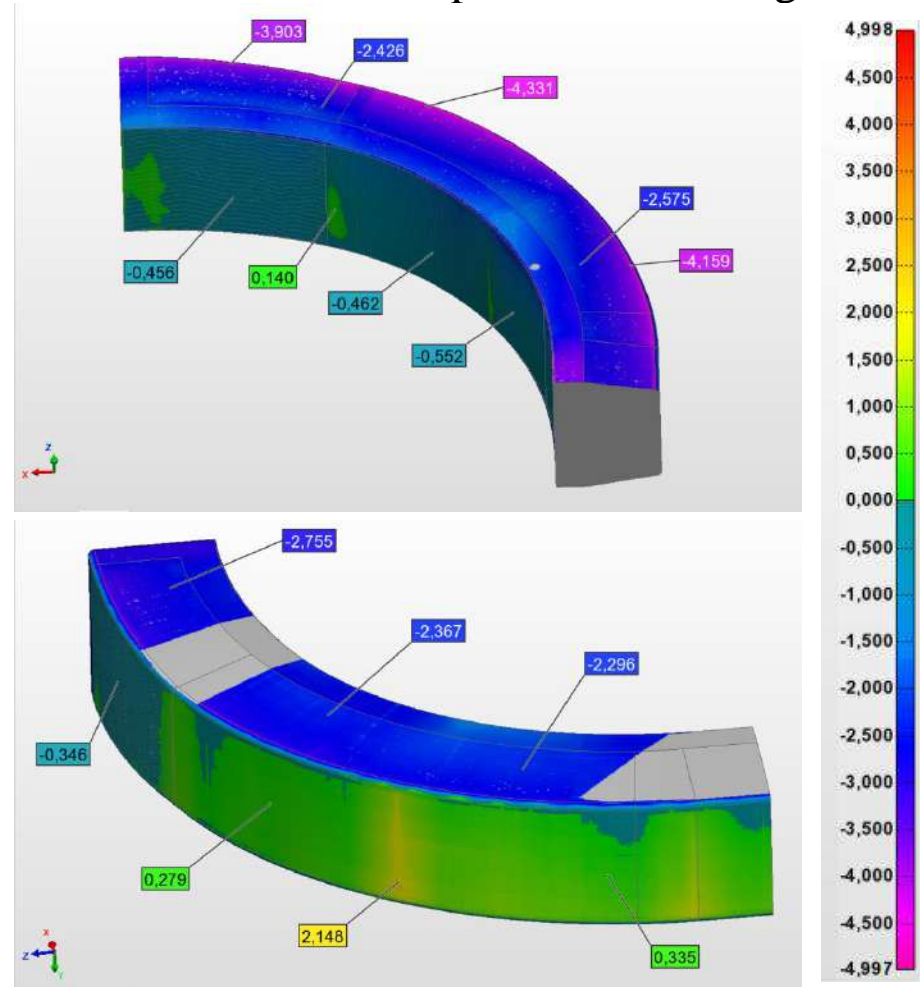
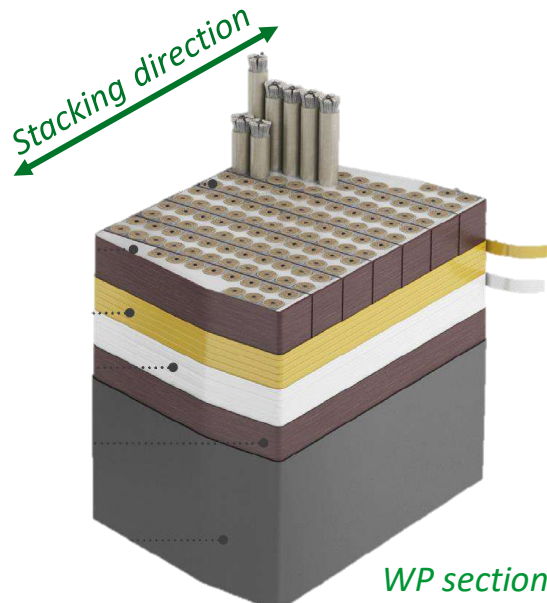

	CAD nominal deviations
AvDev	-1.566
StdDev	1.425
Pts within +/- (1 * StdDev)	1170173 (68.71 %)
Pts within +/- (2 * StdDev)	1680289 (98.66%)
Pts within +/- (3 * StdDev)	1702802 (99.94%)

## Morphing setup:

Four sets of nodes are used to control the morphing of the component.

## Mesh details:

340k nodes

Overall element sizing: 0,05 m

## Morphing details:

Type: STL target

Scan points sampling distance: 0,02 m

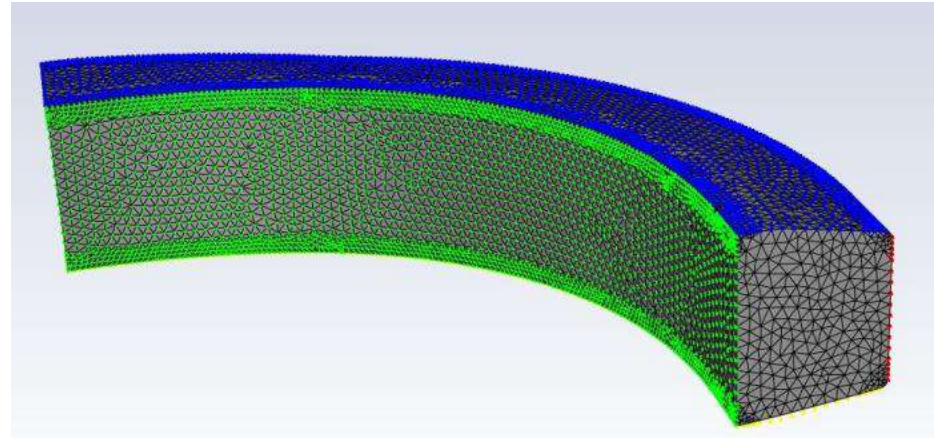

**Top nodes** and **bottom nodes** sets: displacement of 2-4 mm to adapt to the scan

**Inboard nodes** and **outboard nodes** sets: 0,5-2 mm adjustments



## Scan data deviation from morphed CAD:

The morphing and surfaces reconstruction respected the initial CAD topology, and adapted it to the actual manufactured shape.

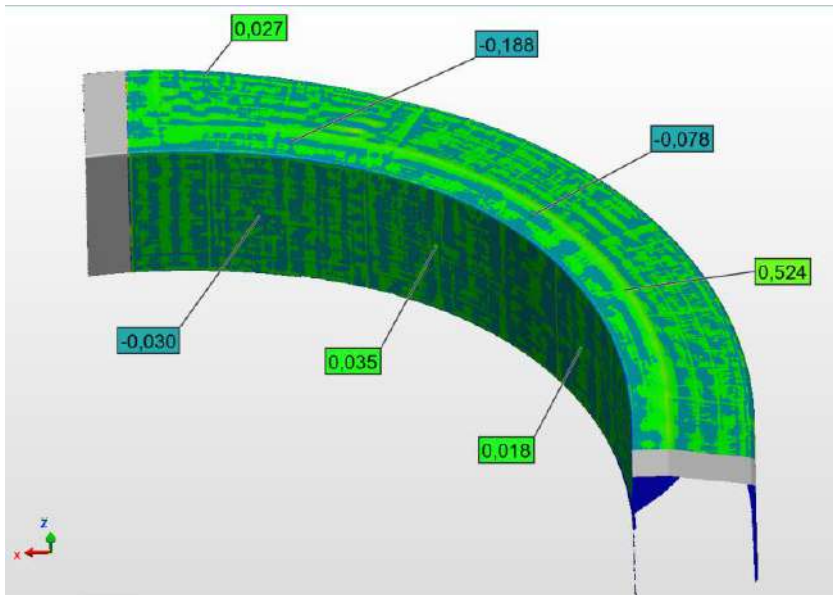

CAD morphed deviations

Method	CAD morphing
AvDev	0.010
StdDev	0.221
Pts within $\pm(1 * \text{StdDev})$	1468351 (86.409%)
Pts within $\pm(2 * \text{StdDev})$	1607505 (94.598%)

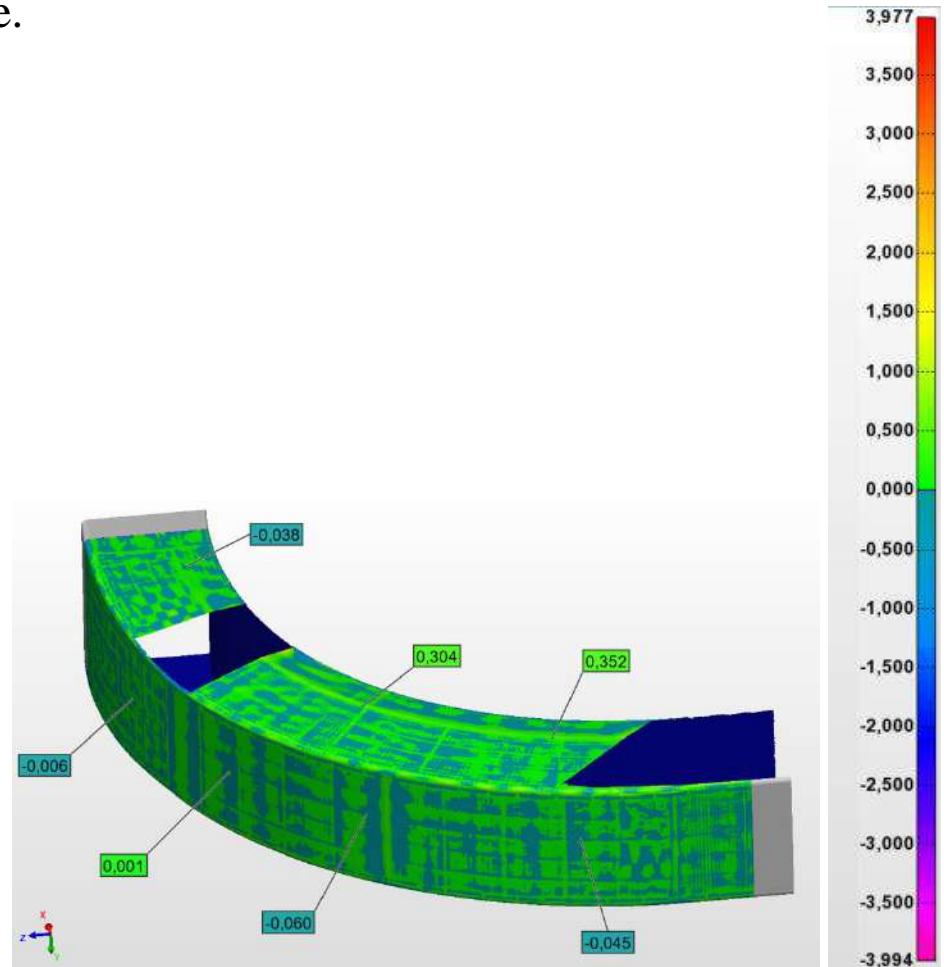

## Comparison with traditional RE techniques:

The methods produce comparable results, both in the standard deviation and in the shape of the Gaussian distribution.

Method	CAD morphing	Traditional RE
AvDev	0.010	0.002
StdDev	0.221	0.087
Pts within +/- (1 * StdDev)	1468351 (86.409%)	495300 (82.362%)
Pts within +/- (2 * StdDev)	1607505 (94.598%)	571248 (94.991%)
Pts within +/- (3 * StdDev)	1658204 (97.581%)	590666 (98.220%)

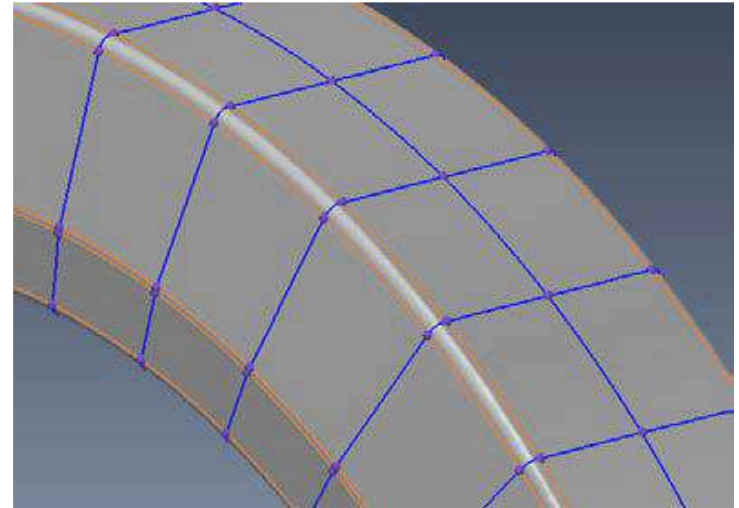

The traditional process generates a different surface topology with respect to the initial configuration.

## Testing environment:

The full scan of the VV IS has been used in the test

*CAD nominal*

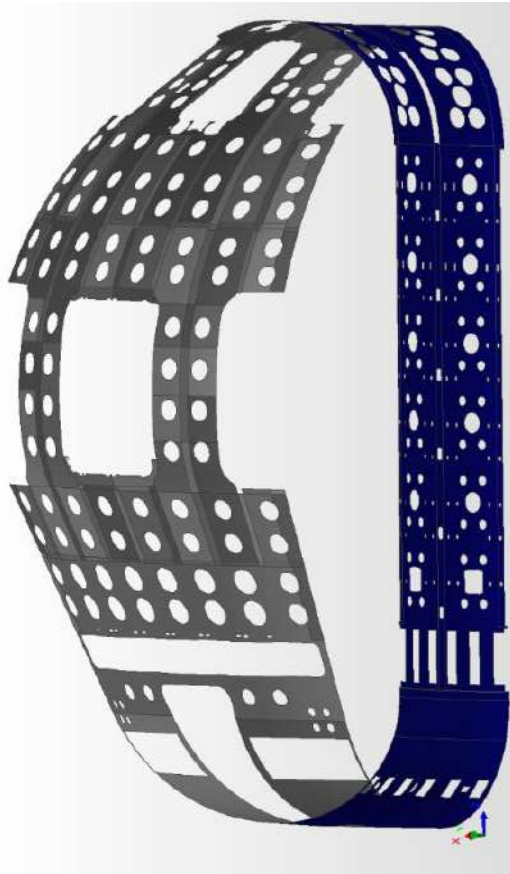

*Scan data*

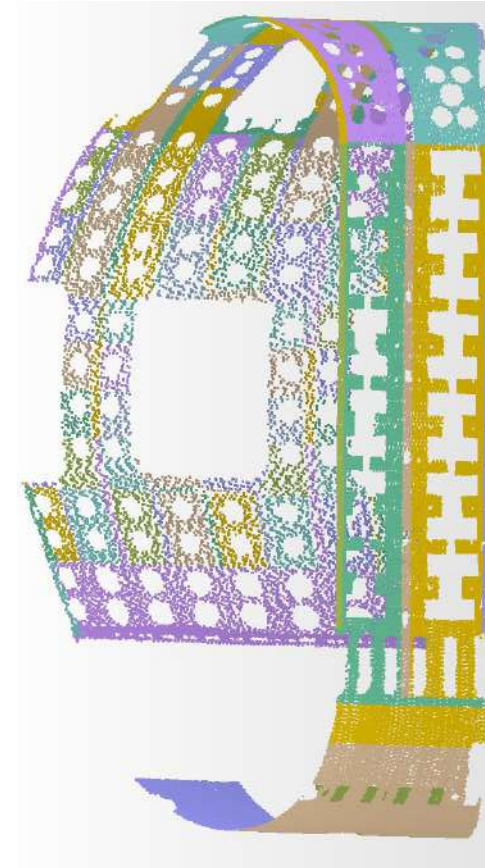

Scan process uncertainty:  $\pm 0.1$  mm

## Scan data deviation from nominal CAD:

The welding process of the single segments produced deviation in the plasma facing surface

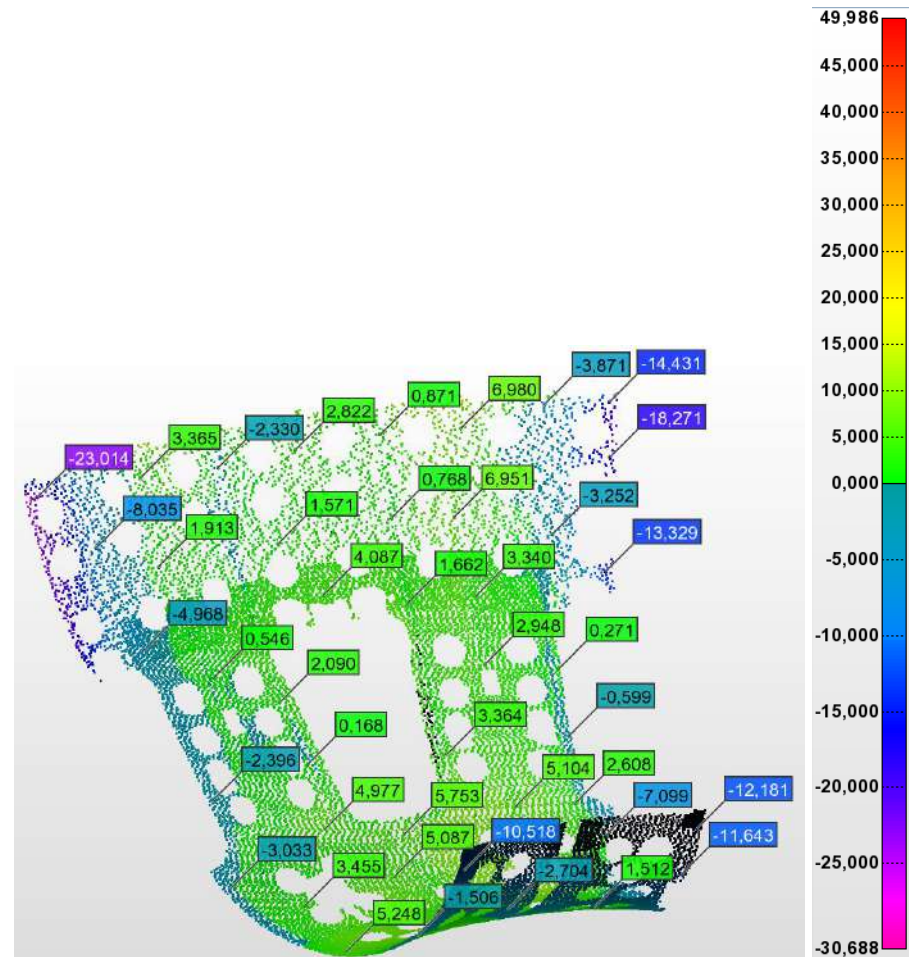
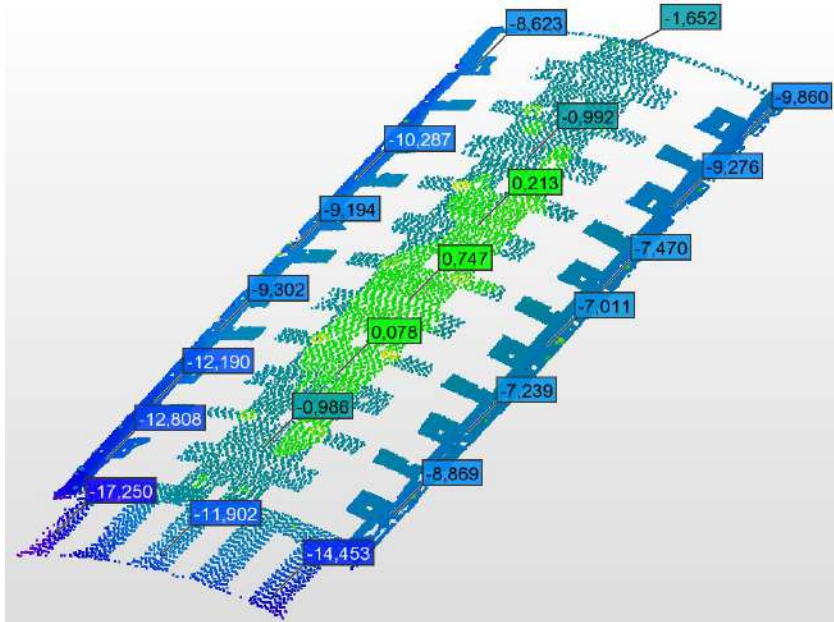

	CAD nominal deviations
AvDev	-1.839
StdDev	6.938
Pts within +/- (1 * StdDev)	65221 (64.437%)
Pts within +/- (2 * StdDev)	98595 (97.410%)
Pts within +/- (3 * StdDev)	101036 (99.821%)

## Scan data deviation from nominal CAD:

The welding process of the single segments produced deviation in the plasma facing surface

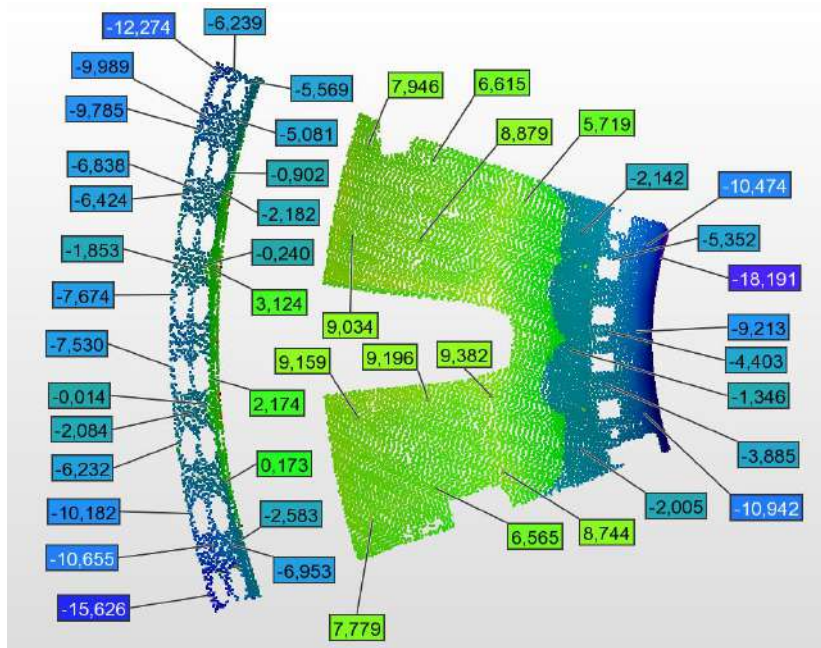

CAD nominal deviations

AvDev	-1.839
StdDev	6.938
Pts within +/- (1 * StdDev)	65221 (64.437%)
Pts within +/- (2 * StdDev)	98595 (97.410%)
Pts within +/- (3 * StdDev)	101036 (99.821%)

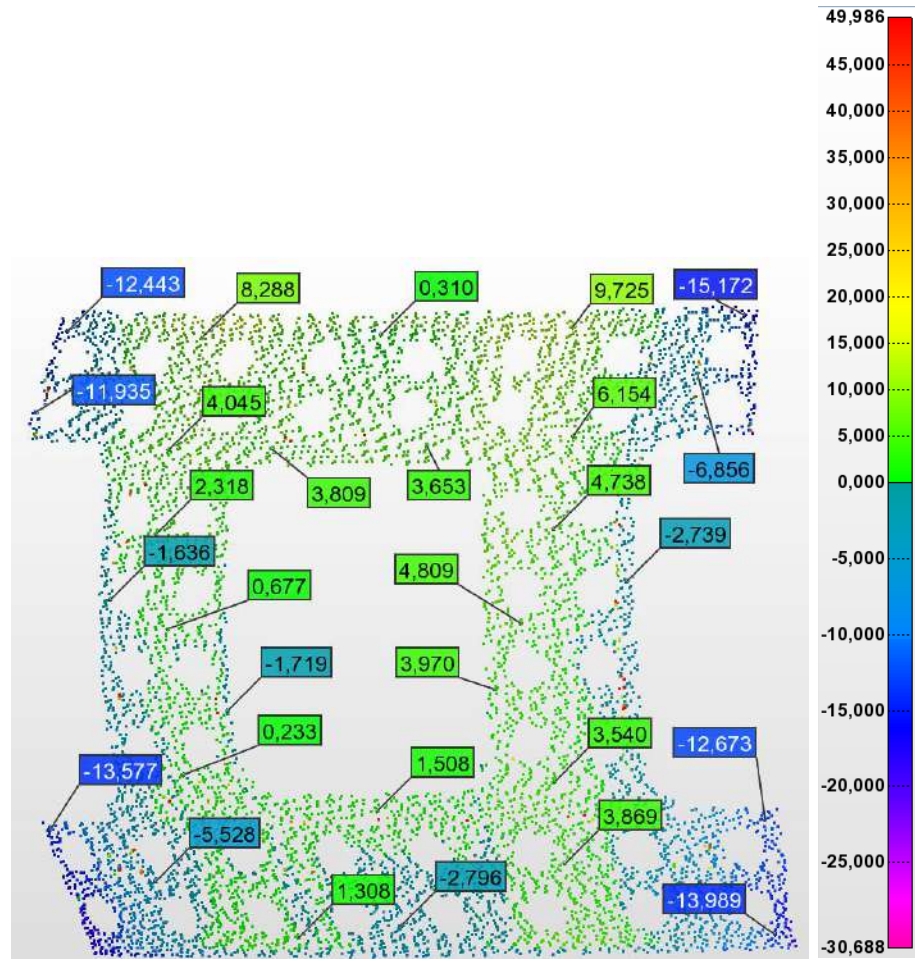

## Morphing setup:

Four sets of nodes, one for each segment, are used to control the morphing.

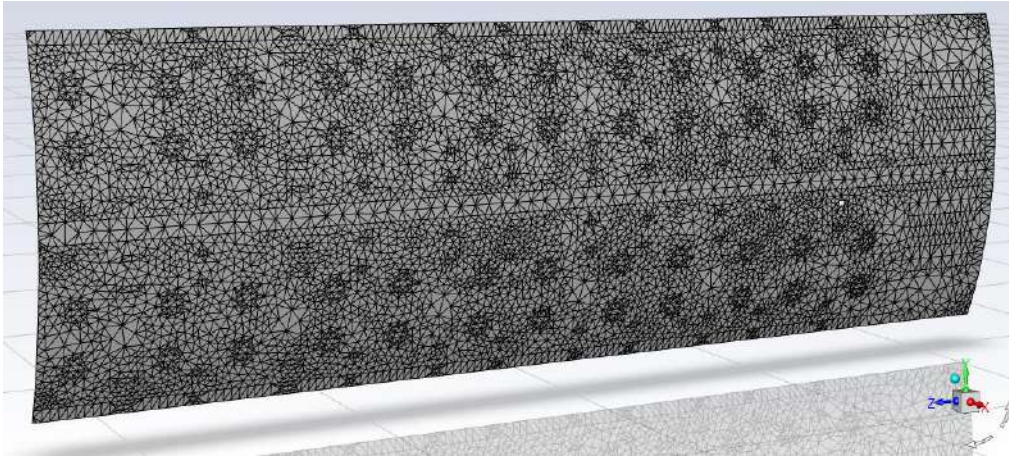

## Mesh details:

1200k nodes

Overall element sizing: 0,01 m

## Morphing details:

Type: STL target

Scan points sampling distance: 0,02 m

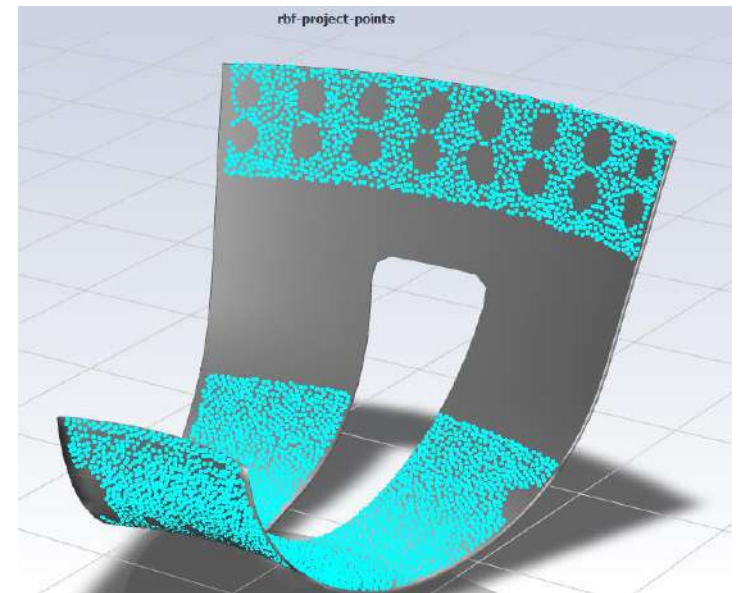

## Scan data deviation from morphed CAD:

The morphing and surfaces reconstruction respected the initial CAD topology, and adapted it to the actual manufactured shape.

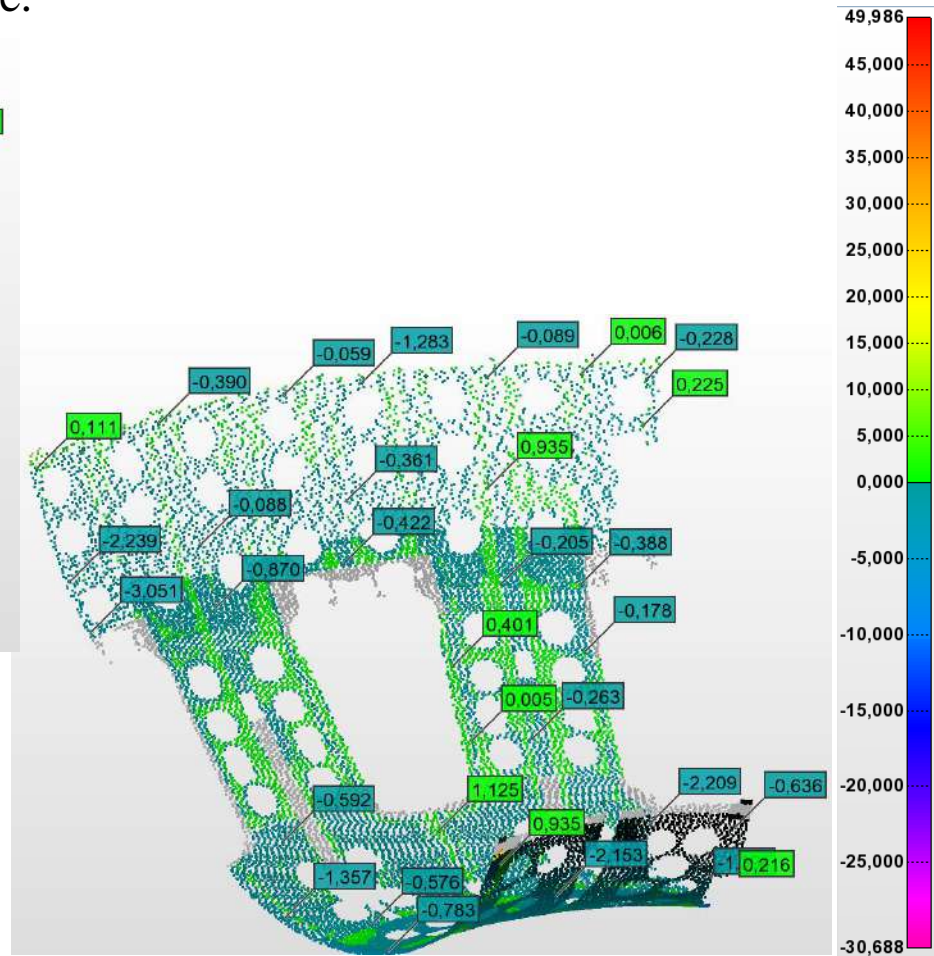
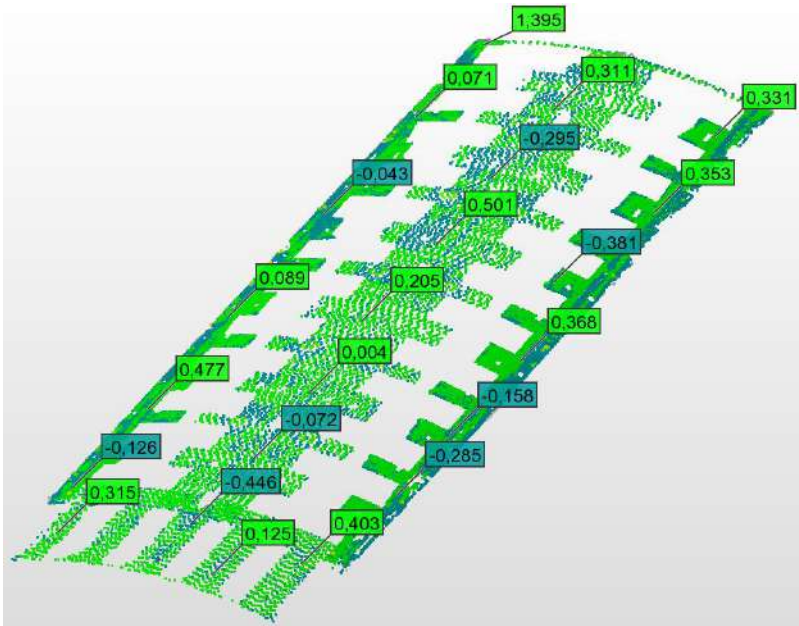

CAD morphed deviations

AvDev	-0.607
StdDev	1.972
Pts within +/- (1 * StdDev)	86448 (88.499%)
Pts within +/- (2 * StdDev)	95065 (97.320%)
Pts within +/- (3 * StdDev)	96744 (99.039%)

## Scan data deviation from morphed CAD:

The morphing and surfaces reconstruction respected the initial CAD topology, and adapted it to the actual manufactured shape.

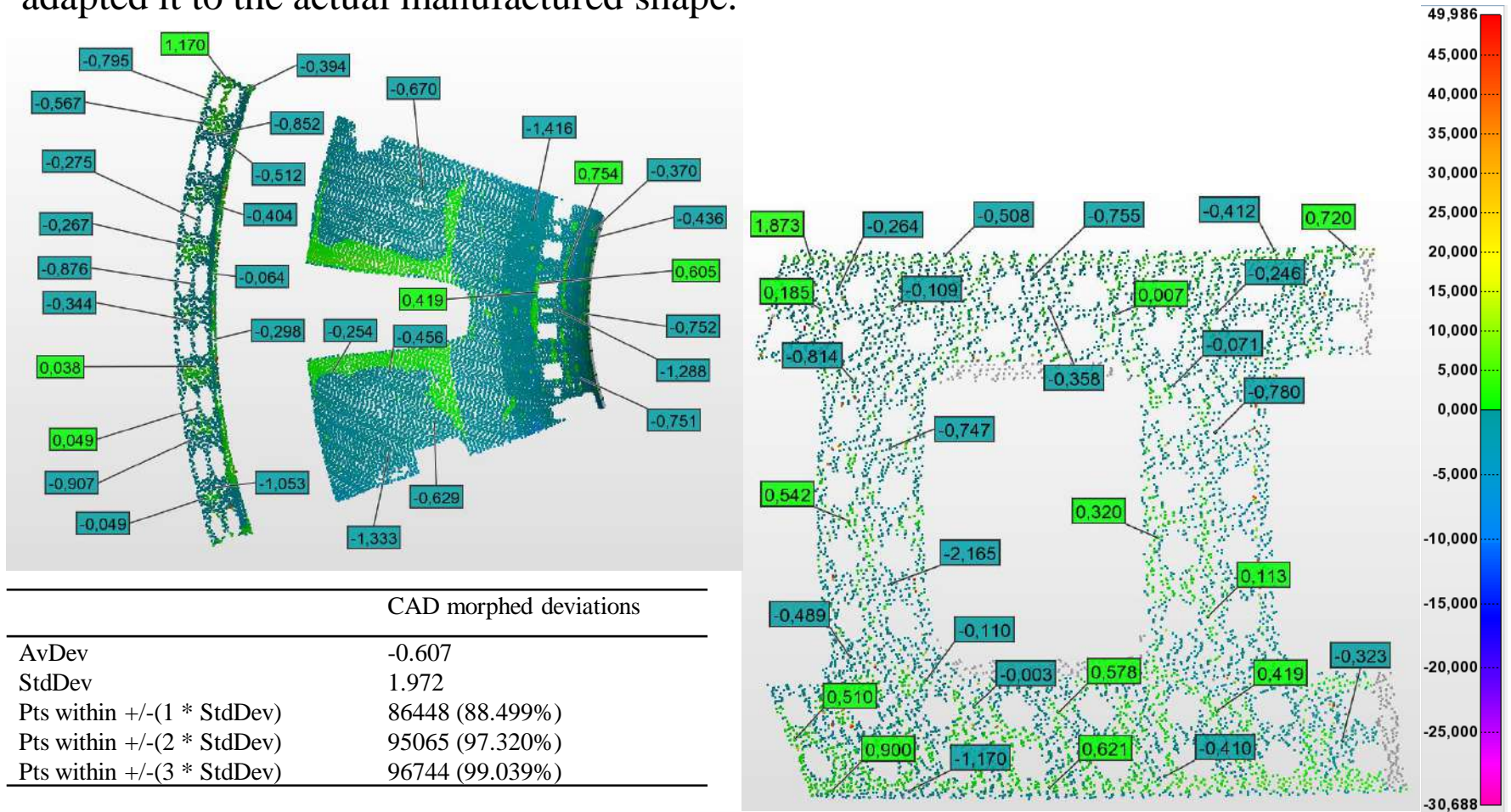



## Association of measurements

In the scope of the standardization of the verification of the ITER components along the manufacturing stages, the implementation of a Skin Model that includes tools for the control of geometric imperfection has been carried out.

- Geometric product specification
- Geometric variation management
- Shape representation

The nominal CAD models of the 7 Coil Cases types have been partitioned, identifying and classifying the features for variant and for required geometrical tolerance.

## Case study: TFC05

The final assembly is composed of the **WP** ( $\text{Nb}_3\text{Sn}$  superconductor) enclosed into its **cases** (namely AU, BU U-shaped cases and AP, BP closure plates).

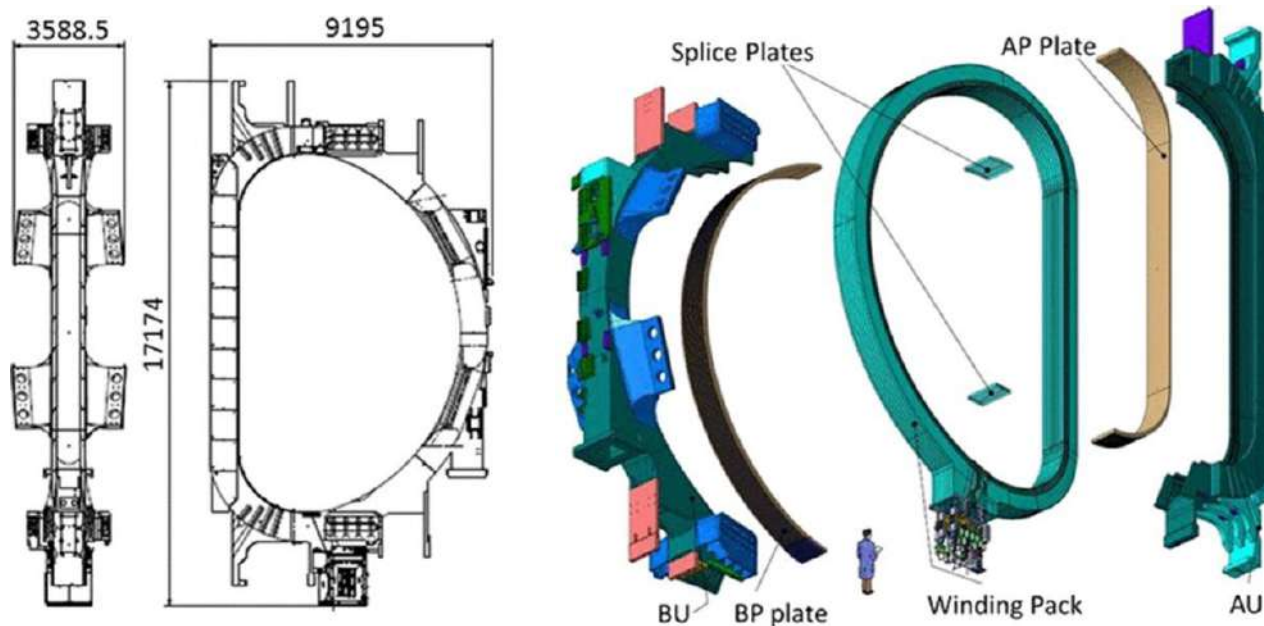

Around 700 checks to be physically measured and verified. The model aims at having an automated tool to ease the post processing and review steps.

## Database:

The model includes the GD&T setup for 7 variants of the coil interfaces (A to G).

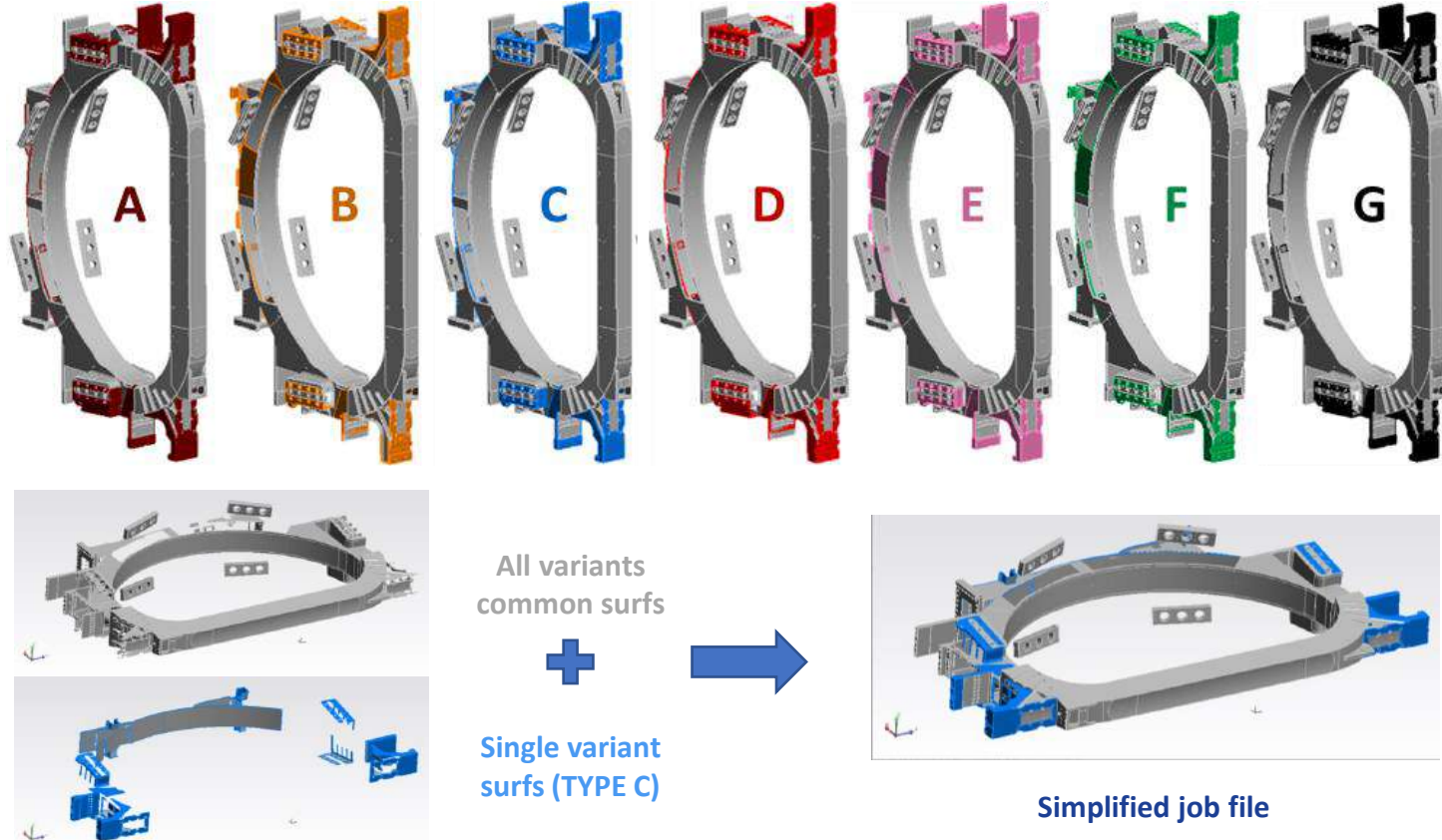

Accessing the database, an automated script helps the operator collecting all the surfaces and checks related to the specific coil type under examination in a single file.

## GD&T setup:

Tolerance requirements can be implemented both with a visual representation and with the regular GD&T descriptors. Automated extraction and association of data to the nominal feature for the computation of compliance.

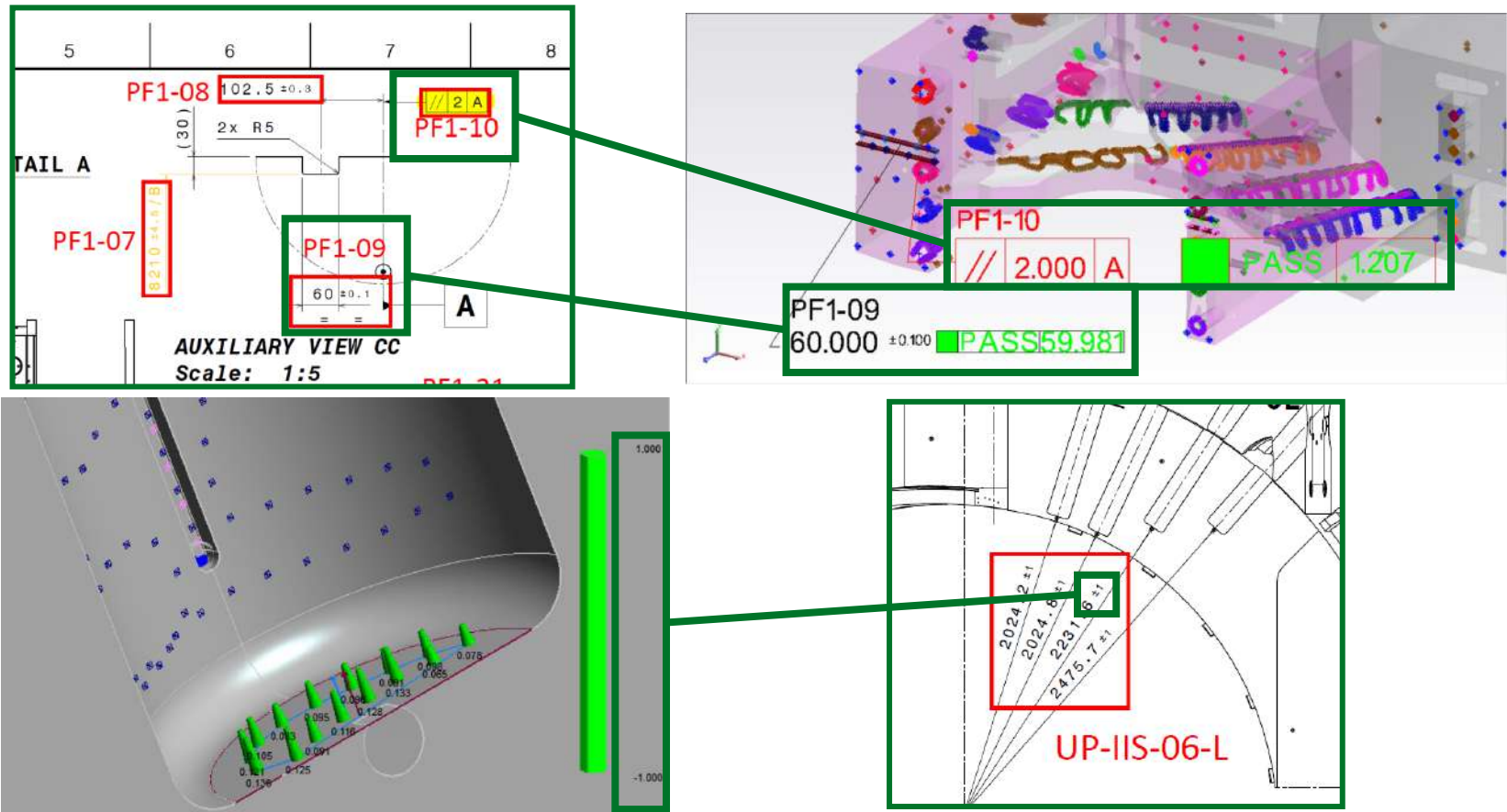

## Virtual Fitting:

Virtual Fitting (VF) is a useful tool in production for the mitigation of risk and decision making.

- Emulate in silico the real fitting of components
- Simulate alignment scenarios to mitigate deviations and out of tolerance
- Linear least square optimization algorithm embedded

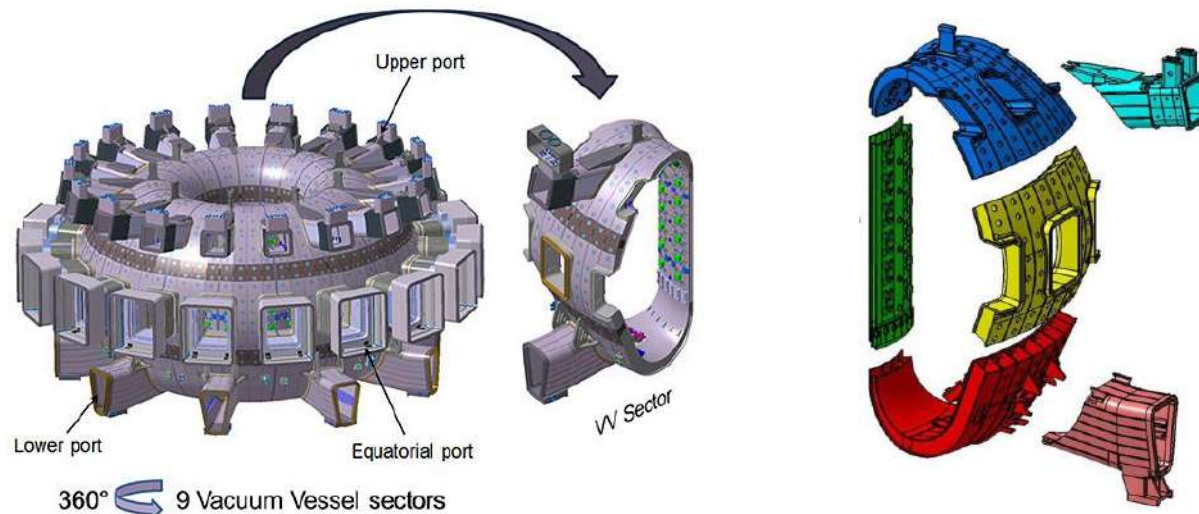

It has been used in the VV project to drive the segments assembly

## Workflow:

Virtual Fitting technique can be applied at different stages of the production. In order to prepare a Virtual Fitting analysis, the following questions have to be answered:

- What is the purpose of the analysis (evaluate assembly, minimize out of tolerances, check contractual alignment, optimize machining)?
- What are the features of interest in the component (interfaces with other components, positional control of non physical features)?



- Association between measured data and features to implement
- Optimization Scenarios

## Vacuum Vessel S5 application:

In the scope of the VV S5 assembly, the scope of the analysis is to find the best compromise in between contractual requirements and segments welding capability

Scenario 1	Scenario 2
Flexible Housings (FH)	Flexible Housings (FH)
Inner Shell (IS)	Inner Shell (IS)
Inner Shell Edge	Inner Shell Edge
Ports Position (PSE)	Ports Position (PSE)
	Segments Weld Step
	Intermodular Keys (IK)
	Centering Keys (CK)

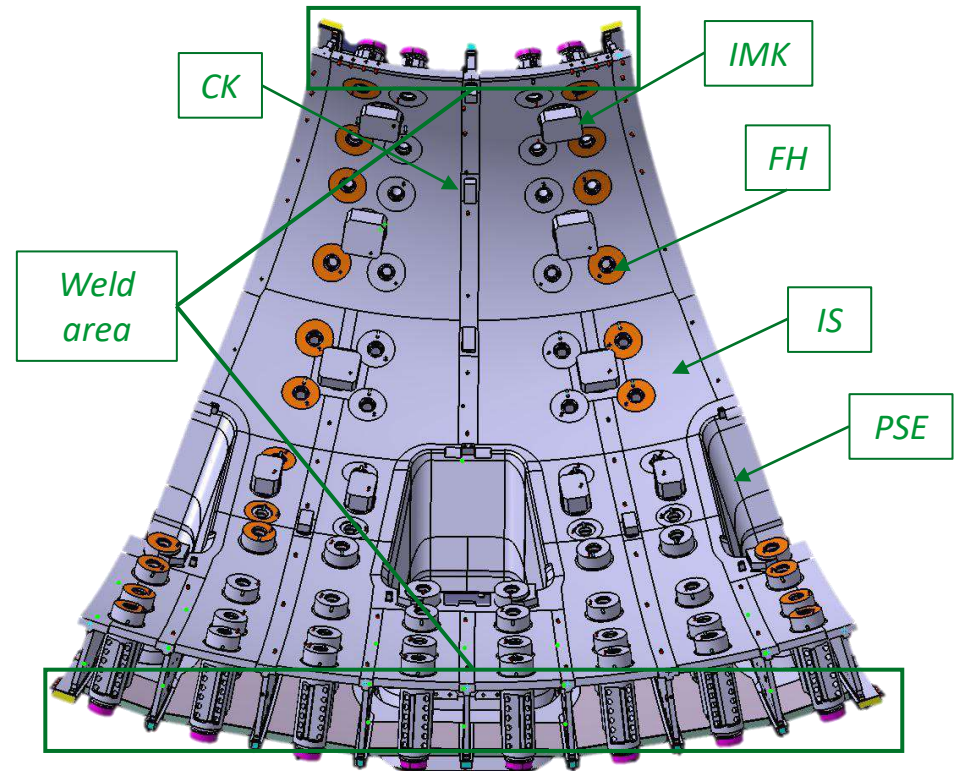

## Feature reconstruction:

Reconstruction of features from measured points:

### Flexible Housing entities reconstructed:

- Bottom point: intersection of bottom plane (best-fit) and cyl axis
- Top point: intersection of offset plane and cyl axis

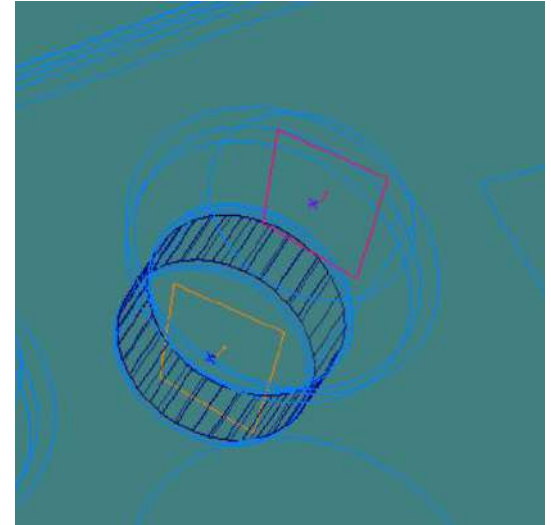

### DATUM entities reconstructed:

- best-fit planes with flexible housing reconstructed points
- bisect plane of the two above planes

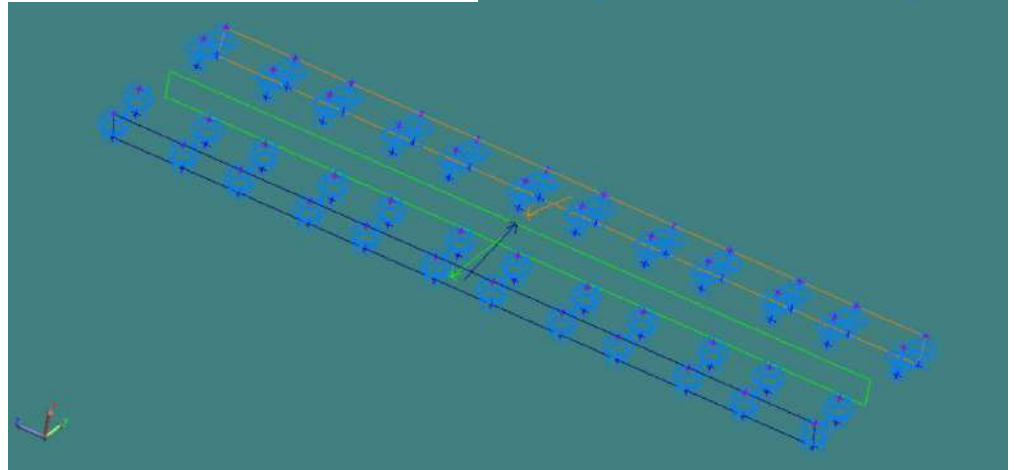



## Features association:

Association of measured data to nominal features: computation of Innes Shell deviation

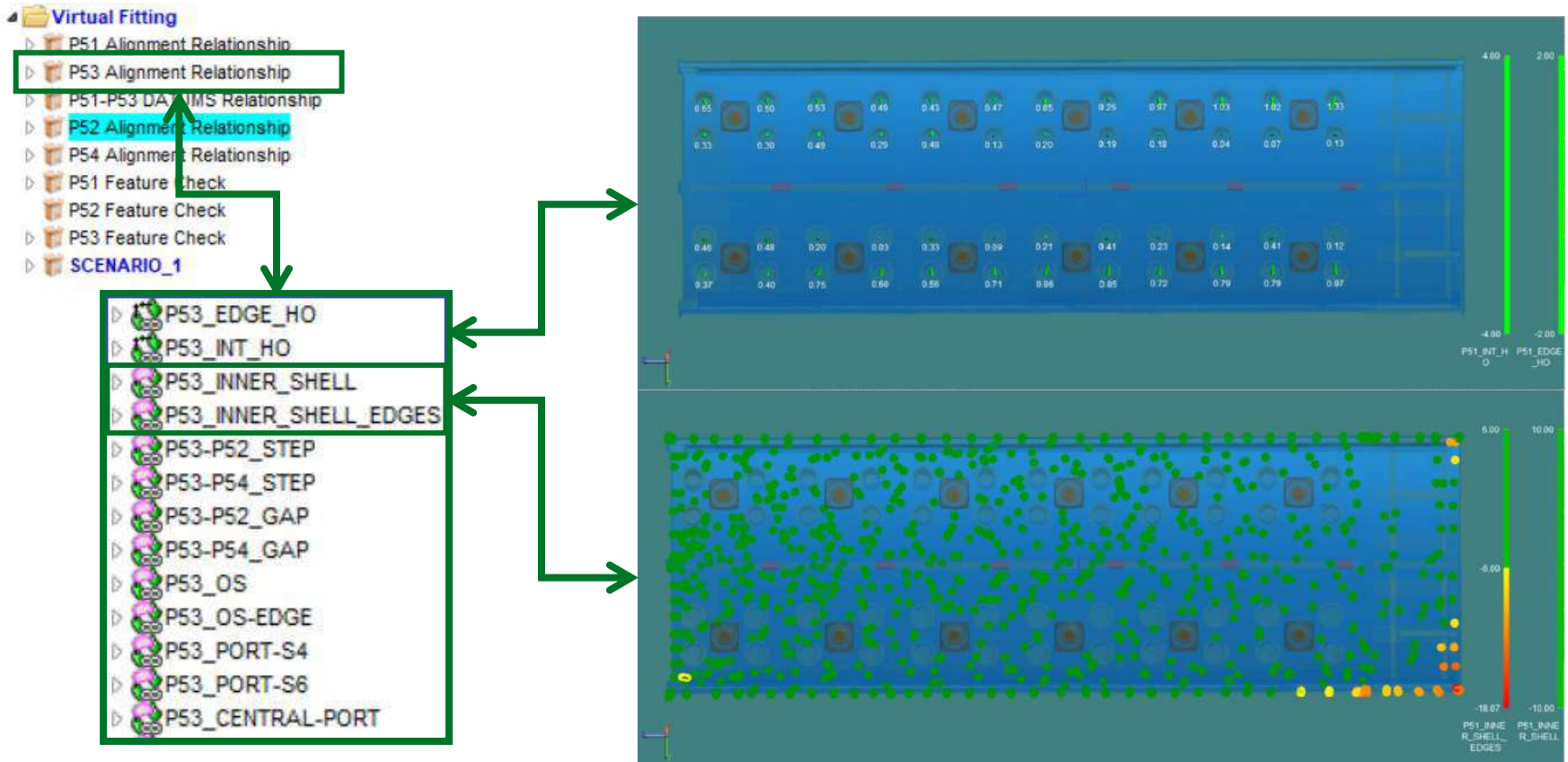

## Features association:

Association of measured data to reconstructed features: gap and step analysis

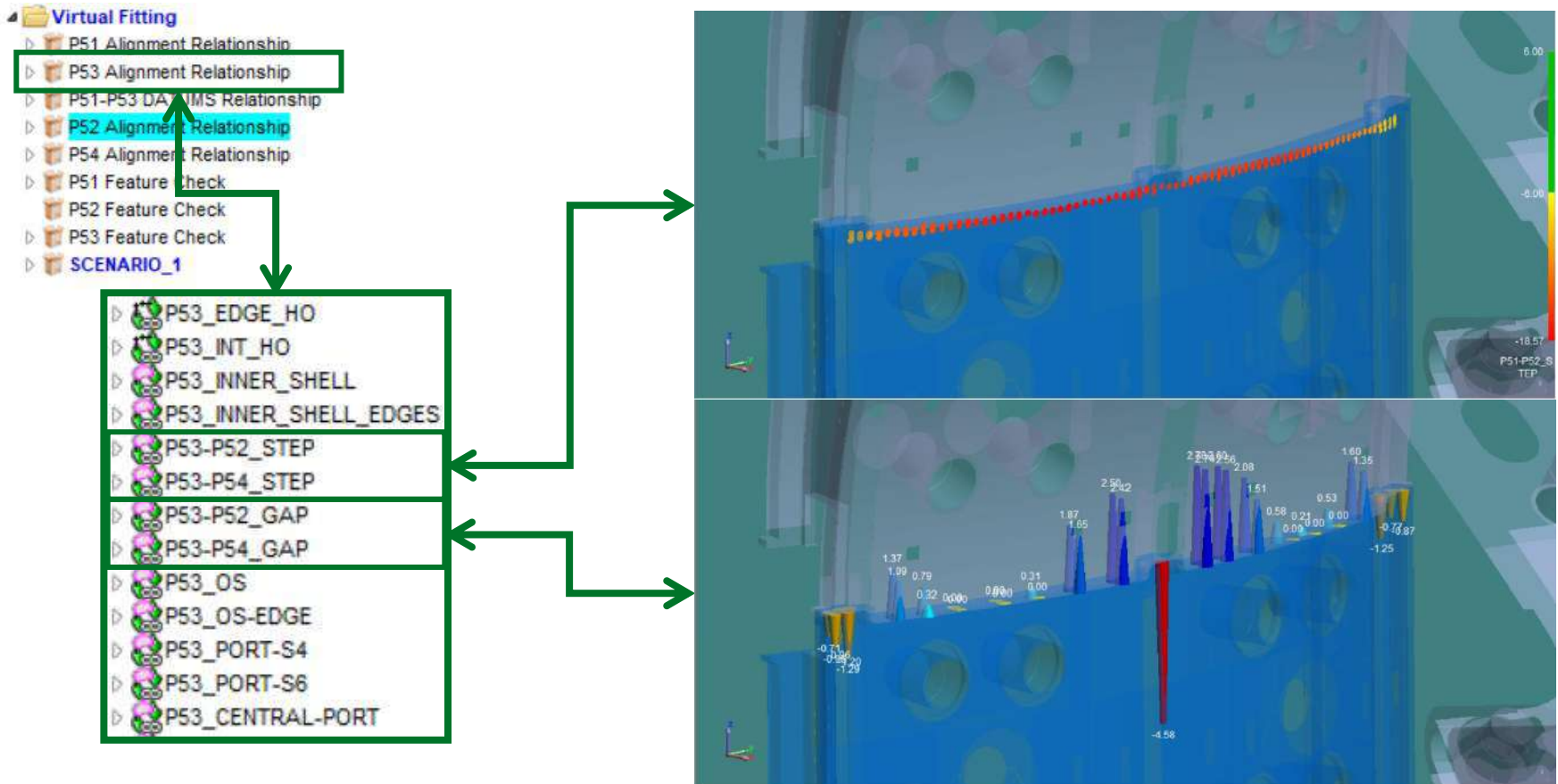

## Linear least square optimization:

The key of the VF: weighted minimization of deviations

$$E_{err}(w_i, e_{RMS,i}) = \sqrt{\sum_{i=1}^N w_i * e_{RMS,i}^2}$$

- Weighting to establish feature priorities and contribution
- Constraints to trigger error computation

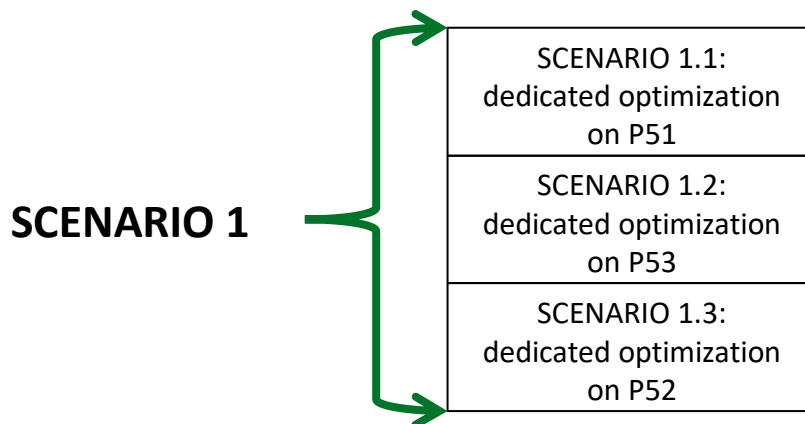

Minimize Relationships

Normalize Weighting

Degrees of Freedom (relative to working frame axes)

X  Y  Z  Rx  Ry  Rz

Rotate about working frame origin  Rotate about centroid

Weight	Relationship	lMax Obj	RMS Obj	Max M
<input type="checkbox"/> 0.680	P51_INNER_SHELL			
<input type="checkbox"/> 0.873	P51_INNER_SHELL_EDGES			
<input checked="" type="checkbox"/> 6.455	P53_EDGE_HO	0.7336	0.4369	
<input checked="" type="checkbox"/> 2.887	P53_INT_HO	0.6412	0.3515	
<input checked="" type="checkbox"/> 0.465	P53_INNER_SHELL	15.6146	6.0850	
<input checked="" type="checkbox"/> 1.353	P53_INNER_SHELL_EDGES	19.3710	10.0127	
<input checked="" type="checkbox"/> 1.339	P53_PORT-S4	8.3257	2.5982	
<input checked="" type="checkbox"/> 1.339	P53_PORT-S6	15.0198	5.6876	
<input checked="" type="checkbox"/> 1.331	P53_CENTRAL-PORT	11.0966	3.2621	
<input type="checkbox"/> 1.000	P52_EDGE_HO_TEMP			
<input type="checkbox"/> 1.000	P52_BODY_HO_TEMP			
<input type="checkbox"/> 1.000	P52_INNER_SHELL			

Equations: 2485, Max Obj: 19.3710, RMS Obj: 6.0239  Show steps

Motion Components

Translation(mm): X = 0.0000, Y = 0.0000, Z = 0.0000

Rotation(deg): Rx = 0.0000, Ry = -0.0000, Rz = 0.0000

Move Manually

Run Optimization

Open Relationship Report

Run Direct Search Optimization

Apply Transformation

Apply Transform and Continue

Cancel. Restore original position

## Vacuum Vessel S5 application:

The strategy has been already implemented for the monitoring of VV S5 manufacturing:

- PS2-PS4 machining
- Segments positioning in assembly rig

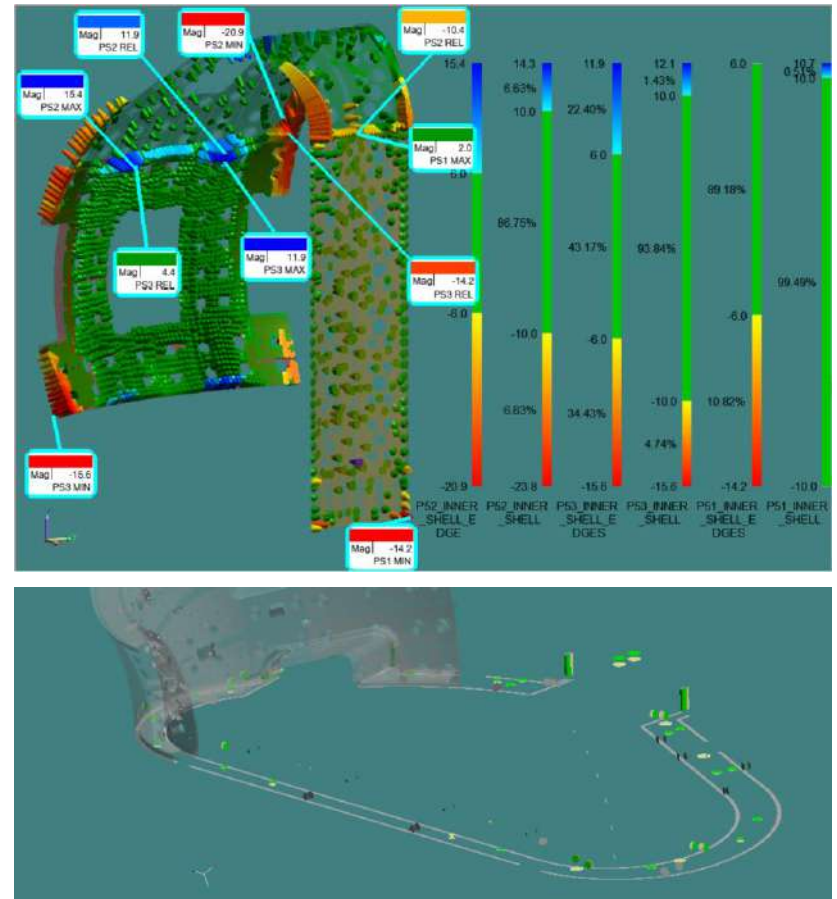
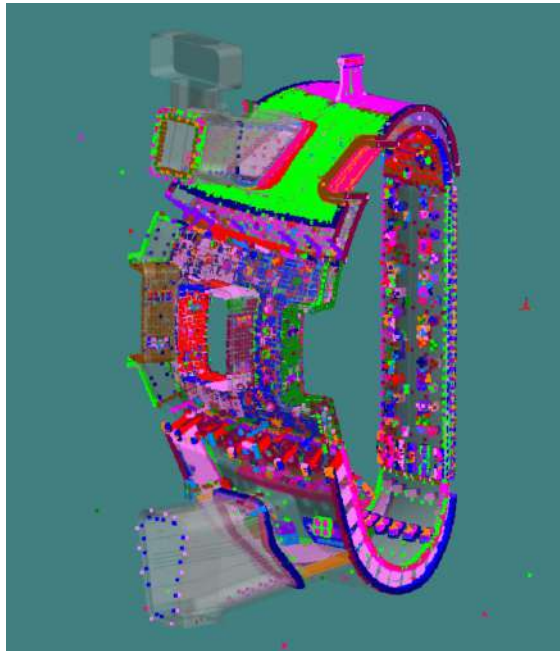

## Conclusions:

An investigation on techniques and methods for the creation of a Digital Twin model has been performed.

- **Reconstruction:** a workflow based on Radial Basis Function morphing and NURBS patching has been developed
- **Association:** Skin Surface model to assess automatically dimensional checks. Virtual Fitting

Basis for future development and integration of these operations in a common environment where the ITER Digital Twin can be built.

FEM models can be integrated in order to monitor the actual performances of the system.

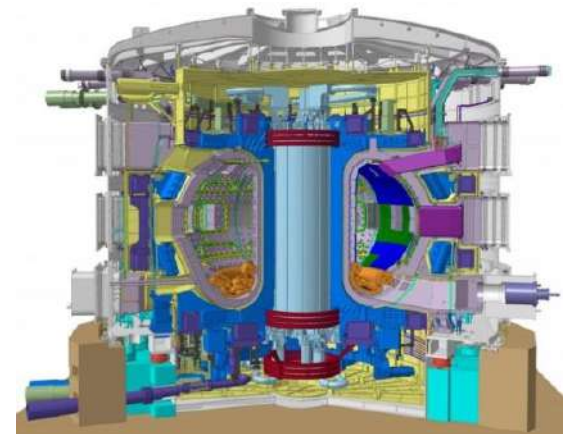



---

# Publications:

The following papers have been published:

- **“F4E load transfer procedure among finite element models different in topology or in discretization”** M. L. Richiusa, R. Forte, E. Pompa, D. Combescure, G. D’Amico, J. A. Pou, A. Portone, P. Testoni, doi: 10.1016/j.fusengdes.2019.01.104
  - **“Crack Propagation Analysis of ITER Vacuum Vessel Port Stub with Radial Basis Functions Mesh Morphing”** E. Pompa, G. D’Amico, S. Porziani, F. Giorgetti, C. Groth, A. Portone, M. E. Biancolini, doi: 10.1016/j.fusengdes.2020.111617
  - **“Crack Propagation Analysis of Near-Surface Defects with Radial Basis Functions Mesh Morphing”** F. Giorgetti, R. Cenni, A. Chiappa, M. Cova, C. Groth, E. Pompa, S. Porziani, M. E. Biancolini, doi: 10.1016/j.prostr.2018.11.071
  - **“Current Centre Line integration in the manufacturing process of the ITER Toroidal Field Coils”** M. Jimenez et al., doi: 10.1109/TASC.2020.2971472.
  - **“Comparison of FEM Predicted and Measured values of the TF coil closure welding distortion, ”** E. Pompa M. Jimenez, G. D’Amico, B. Bellesia, A. Bonito-Oliva, A. Portone, doi: 10.1109/TASC.2020.2965465
  - **“High fidelity numerical fracture mechanics assisted by RBF mesh morphing”** C. Groth, S. Porziani, A. Chiappa, E. Pompa, R. Cenni, M. Cova, G. D’Amico, F. Giorgetti, C. Brutti, P. Salvini, M. Rochette, M. E. Biancolini
  - **“Progress on European ITER Toroidal Field Coil Procurement: Cold Test and Insertion Work Package”** B. Bellesia, P. Aprili, A. B. Oliva, E. Boter, A. Calin, M. Paz Casas, M. Cornelis, P. Figueiredo, J. C. Garcia, R. Harrison, A. Hernandez, M. Jimenez, S. Koczorowski, C. Kostopoulos, K. Libens, A. Lo Bue, C. Luongo, E. Pompa, L. Poncet, E. Pozuelo, N. S. Pellicer, E. Viladiu, P. Barbero, E. Theisen
  - **“Toward Completion and Delivery of the First EU ITER Magnets”** A. B. Oliva, P. Aprili, B. Bellesia, E. Boter, T. Boutboul, P. C. de Sousa, M. P. Casas, M. Cornelis, P. Gavouyere-Lasserre, R. Harrison, A. Hernandez, M. Jimenez, A. Loizaga, M. Martinez, P. Readman, G. Romano, D. Rossi, C. Sborchia, P. Valente, E. Viladiu, R. Batista, V. Casarin, C. Kostopoulos, A. Lo Bue, E. Pompa, E. Pozuelo-Segura, B. Su Lim, S. Koczorowski, C. Luongo, N. Mitchell, L. Poncet
  - **“CAD model update on as-built geometries with morphing technique: ITER winding pack”** E. Pompa, S. Porziani, C. Groth, A. Chiappa, G. D’Amico, E. Costa, S. Sorrentino, E. Ferrante, A. Portone, L. Semeraro, M. E. Biancolini
- 
- 



**TOR VERGATA**  
UNIVERSITÀ DEGLI STUDI DI ROMA



**Edoardo Pompa**

for

**PhD Program in Design, Manufacturing and Operations  
Engineering**

**Thank you for your attention!**

Academic Institution: [University of Rome “Tor Vergata”](#), Italy

**Advisors:** Marco E. Biancolini (UTV), Gabriele D’Amico (F4E), Alessandro Lo Bue (F4E)